



Date: - 30th April, 2026

BSE Ltd. Regd. Office: Floor - 25, Phiroze Jeejeebhoy Towers, Dalal Street, Mumbai-400 001. BSE Scrip Code: 543300	National Stock Exchange of India Ltd. Listing Deptt., Exchange Plaza, Bandra Kurla Complex, Bandra (East), Mumbai - 400 051 NSE Scrip: SONACOMS
---	--

Subject: - Investor Presentation on the financial results for quarter and financial year ended on 31st March, 2026.

Dear Sir / Madam,

In compliance with Regulation 30 read with Para 15(a) of Part A of Schedule III and other applicable provisions of the Securities and Exchange Board of India (Listing Obligations and Disclosure Requirements) Regulations, 2015, we have enclosed herewith the Investor Presentation inter-alia, encompassing an overview of the Company, its operations and unaudited Standalone and Consolidated Financial Results for the quarter and financial year ended on 31st March, 2026.

Kindly take the same on record.

Thanking you,
For Sona BLW Precision Forgings Limited

Arjun Singh
Compliance Officer

Enclosed: As above



SONA COMSTAR

Q4 FY26 Earnings Presentation

30 April 2026

Disclaimer

This presentation and the accompanying slides (the "Presentation"), which have been prepared by Sona BLW Precision Forgings Ltd. (the "Company"), have been prepared solely for information purposes and do not constitute any offer, recommendation or invitation to purchase or subscribe for any securities, and shall not form the basis or be relied on in connection with any contract or binding commitment whatsoever. No offering of securities of the Company will be made except by means of a statutory offering document containing detailed information about the Company.

This Presentation has been prepared by the Company based on information and data which the Company considers reliable, but the Company makes no representation or warranty, express or implied, whatsoever, and no reliance shall be placed on, the truth, accuracy, completeness, fairness and reasonableness of the contents of this Presentation. This Presentation may not be all inclusive and may not contain all of the information that you may consider material. Any liability in respect of the contents of, or any omission from, this Presentation is expressly excluded.

Certain matters discussed in this presentation may contains certain forward-looking statements concerning the Company's future business prospects and business profitability. Such forward-looking statements are not guarantees of future performance and are subject to a number of risks and uncertainties that are difficult to predict. These risks and uncertainties include, but are not limited to, the Company's ability to manage growth, the fluctuations in earnings, competition (both domestic and international), economic growth in India and abroad, ability to attract and retain highly skilled professionals, time and cost over runs on contracts, the Company's ability to manage its international operations, Government policies and actions regulations, interest and other fiscal costs generally prevailing in the economy. The Company does not undertake to make any announcement in case any of these forward-looking statements become materially incorrect in future or update any forward-looking statements made from time to time by or on behalf of the Company.

© Sona BLW Precision Forgings Limited (Sona Comstar). Reproduction and distribution of this Presentation without the permission of Sona Comstar is prohibited.

**Bigger Bets.
Bolder Moves.
Beyond Boundaries.**

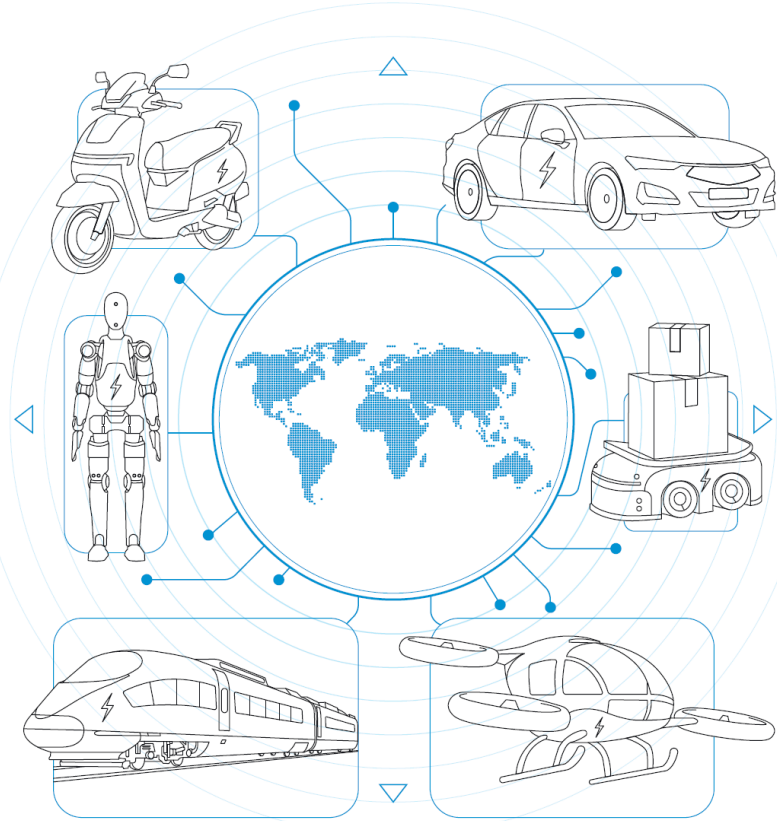

Our Management



Mr. V. Vikram Verma
*Whole Time Director and
CEO, Driveline Business*



Mr. Sat Mohan Gupta
CEO, Motor Business



**Mr. Praveen
Chakrapani Rao**
Group CTO



Mr. Rohit Nanda
Group CFO



Mr. Vivek Vikram Singh
MD & Group CEO



Mr. Amit Mishra
Head, Railway Business



SONA COMSTAR NOVELIC

MOVING MOBILITY FORWARD.
ELECTRIC. PERSONALIZED. INTELLIGENT. CONNECTED.

MOBILITY
SOLUTIONS FOR COMMERCIAL VEHICLES

STEP UP

IN-CABIN MONITORING

ELECTRONICALLY LOCKING DIFFERENTIAL



NOVELIC ASPER 180° FOV 79 GHZ RADAR SENSOR
LIVE DEMO

PARK ASSIST 2.0



ICAN500
IN MASS PRODUCTION

SEE RADAR VEHICLE...

Business Performance Highlights

Our Booth at Consumer Electronics Show 2026

Q4 FY26 Financial Performance Highlights

12,723 mn | 47%

Revenue | YoY Growth

3,106 mn | 32%

EBITDA | YoY Growth

1,919 mn | 17%

PAT | YoY Growth

24.4% EBITDA Margin

14.7% PAT Margin¹

3,588 mn | 22%

BEV Revenue | YoY Growth

39%

BEV Share in
Automotive Product Revenue²

Notes:

1. PAT margin percentage calculated from PAT including non-controlling interest
2. Includes product revenue from PV, CV, OHV, E2W, E3W vehicle segments

FY26 Financial Performance Highlights

44,751 mn | **26%**

Revenue | YoY Growth

11,069 mn | **13%**

EBITDA | YoY Growth

6,703 mn | **11%**

Adjusted PAT¹ | YoY Growth

24.7% EBITDA Margin

14.7% PAT Margin²

15.4%

RoCE³

13.2%

RoE⁴

Notes:

1. Adjusted PAT is after adjusting the one-time impact of ₹301 mn due to the new labour code
2. PAT margin percentage calculated from PAT including non-controlling interest
3. ROCE = LTM EBIT/(Average tangible capital employed + capital deployed for acquiring NOVELIC and Railway Business)
4. ROE = LTM PAT/(Average tangible net worth + capital deployed for acquiring NOVELIC and Railway Business); LTM PAT is adjusted for one-time impact of ₹301 mn due to the new labour code



Update on our Strategic Priorities

Our Integrated Motor Controllers, EVTOL Gearbox, and AMR Drive Unit at CES 2026

Update on our Strategic Priorities



Electrification



**Global Market
Significance**

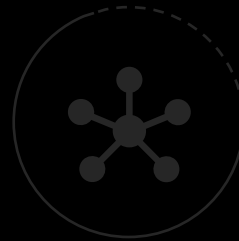

Diversification

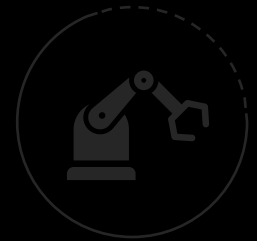

Technology

Sizeable and Increasing Presence in EVs

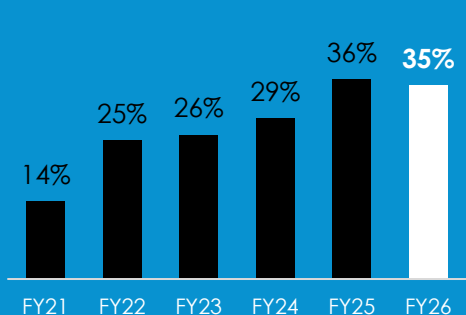

BEV Share in Automotive Product Revenue¹

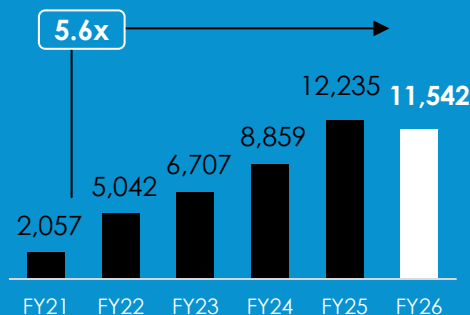

BEV Segment Revenue

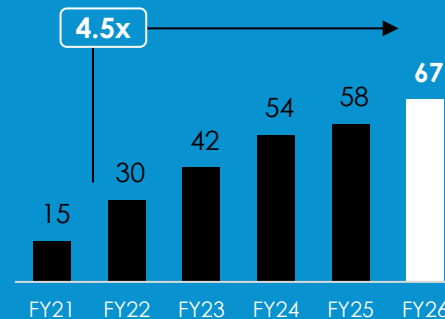

Cumulative no. of EV Programs Awarded

$$\frac{64}{(19+14+31)^2}$$

EV Programs² awarded across 33 customers as at the end of Q3 FY26

+3

$$\frac{67}{(20+17+30)^2}$$

EV Programs² awarded across 35 customers as at the end of Q4 FY26

Notes:

1. Includes product revenue from PV, CV, OHV, E2W, E3W vehicle segments
2. Include only BEV and PHEV programs currently in serial production as well as in the orderbook; numbers in brackets to be read as (# of programs in fully ramped up production + # of programs in ramp-up + # of programs not yet in production)

In Q4 we had three EV and one hybrid driveline program wins spread across all our key geographies



For Battery Electric Passenger Vehicles



Differential Gears

New Customer

European OEM of PVs and EVs

₹2,200 mn

addition in our orderbook

H1 FY29

Start of Production



Differential Assembly

New Customer

European OEM of PVs and EVs

₹1,400 mn

addition in our orderbook

H1 FY28

Start of Production



Differential Assembly

Existing Customer

European OEM of PVs and EVs + Indian OEM of PVs, CVs, and EVs

₹1,000 mn

addition in our orderbook

H1 FY28

Start of Production

For Hybrid Passenger Vehicles



Differential Assembly

Existing Customer

European OEM of PVs and EVs

₹1,200 mn

addition in our orderbook

H2 FY28

Start of Production

Our Strategic Priorities



Electrification



Global Market
Significance

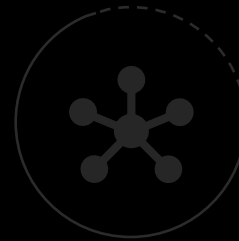

Diversification



Technology

Orders worth ₹57 billion were added to our orderbook during FY26



Net Orderbook (Rs. Billion)

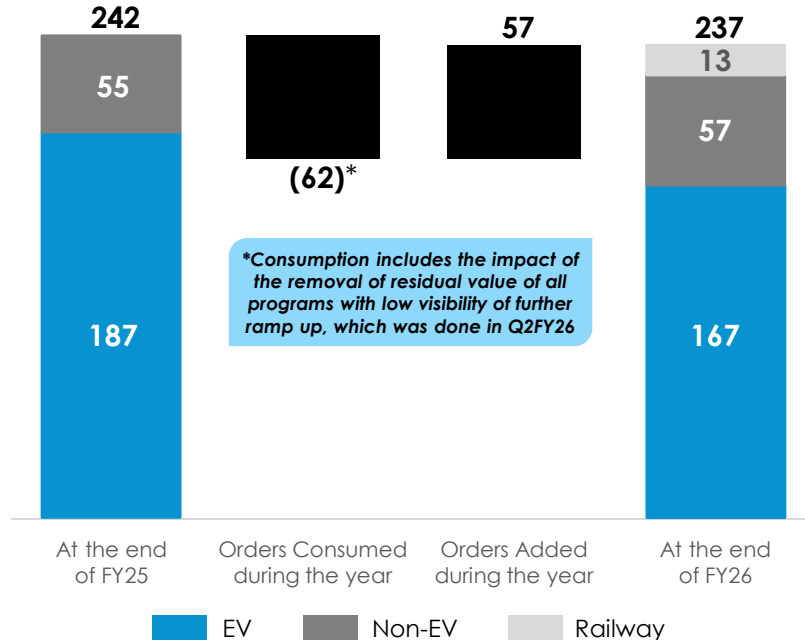

31 Programs won in FY26

3 New customers added in FY26

Global Market Share of Differential Gears
 CY24¹ **8.8%** → **8.7%** CY25¹

Global Market Share of Starter Motors
 CY24¹ **4.4%** → **4.2%** CY25¹

Notes:

1. As per CRISIL's market size estimates for CY24 and company analysis for CY25

Our net order book¹ stands at ₹237 billion (5.3x FY26 revenue)

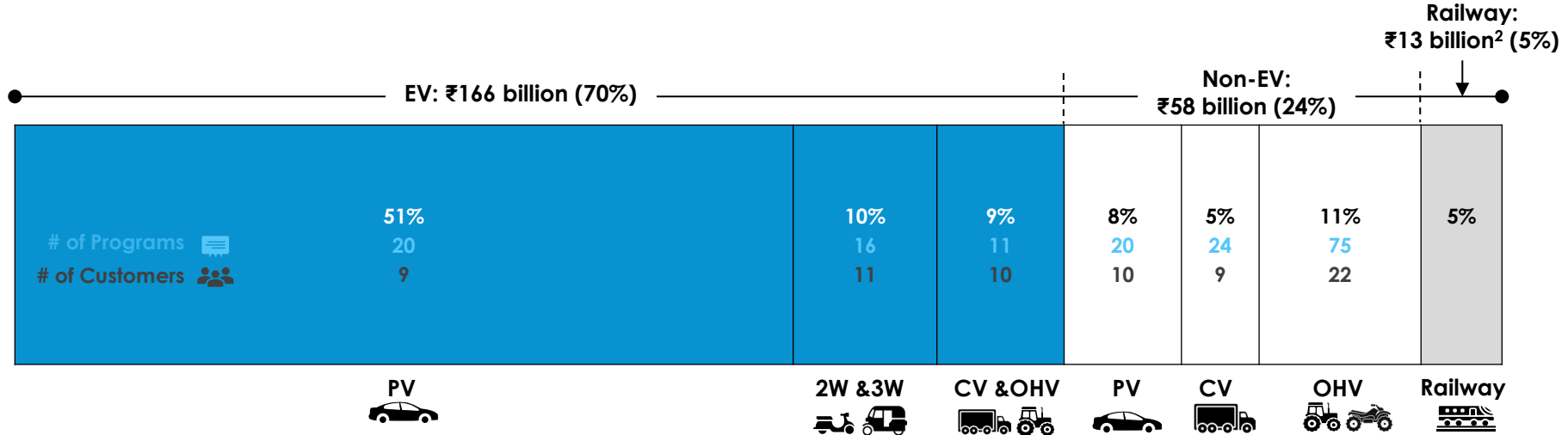

Notes:

- Net order book means the aggregate revenue from awarded programs which are either yet to start production or are yet to fully ramp up, in the next 10 years, after adjusting for the negative impact of all programs that are expected to reach end of life or be phased out. We have also applied a discount to accommodate any unforeseen delays or changes in program launches that may happen in the future.
- Railway business order book is based on the purchase orders received from the customers to be executed largely within next 12 months

Our Strategic Priorities



Electrification



Global Market
Significance

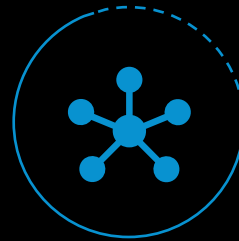

Diversification



Technology

Diversified Revenue Mix



By Geography

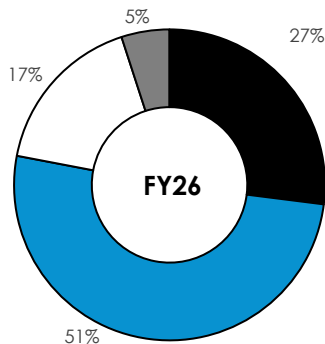
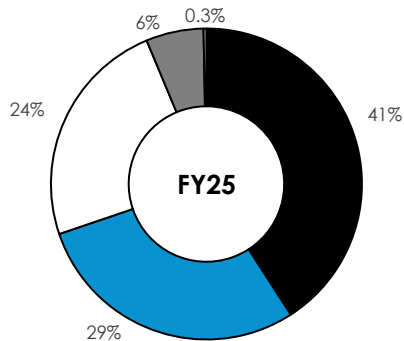

■ North America ■ India □ Europe ■ Asia (excl. India) □ RoW

By Product

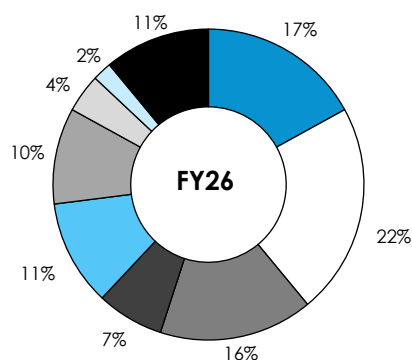
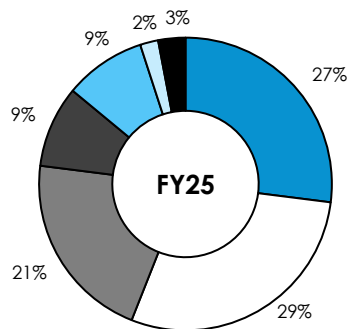

■ Differential Assembly □ Differential Gears
 ■ Micro/Plug-in Hybrid Starter Motors ■ Conventional Starter Motors
 ■ Traction & Suspension Motors ■ Railway-Brake systems
 □ Railway Suspension & Coupler □ Sensors and Software
 ■ Others

By Market segment

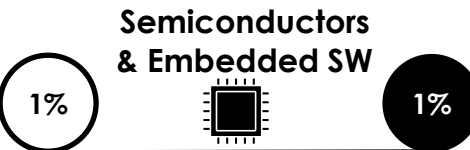
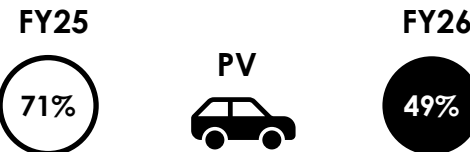

Our Strategic Priorities



Electrification



Global Market
Significance

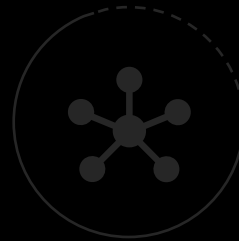

Diversification



Technology

Our Technology Roadmap for E.P.I.C. Mobility

Harnessing capabilities to continue our journey from components to subsystems to systems in all areas of EPIC mobility

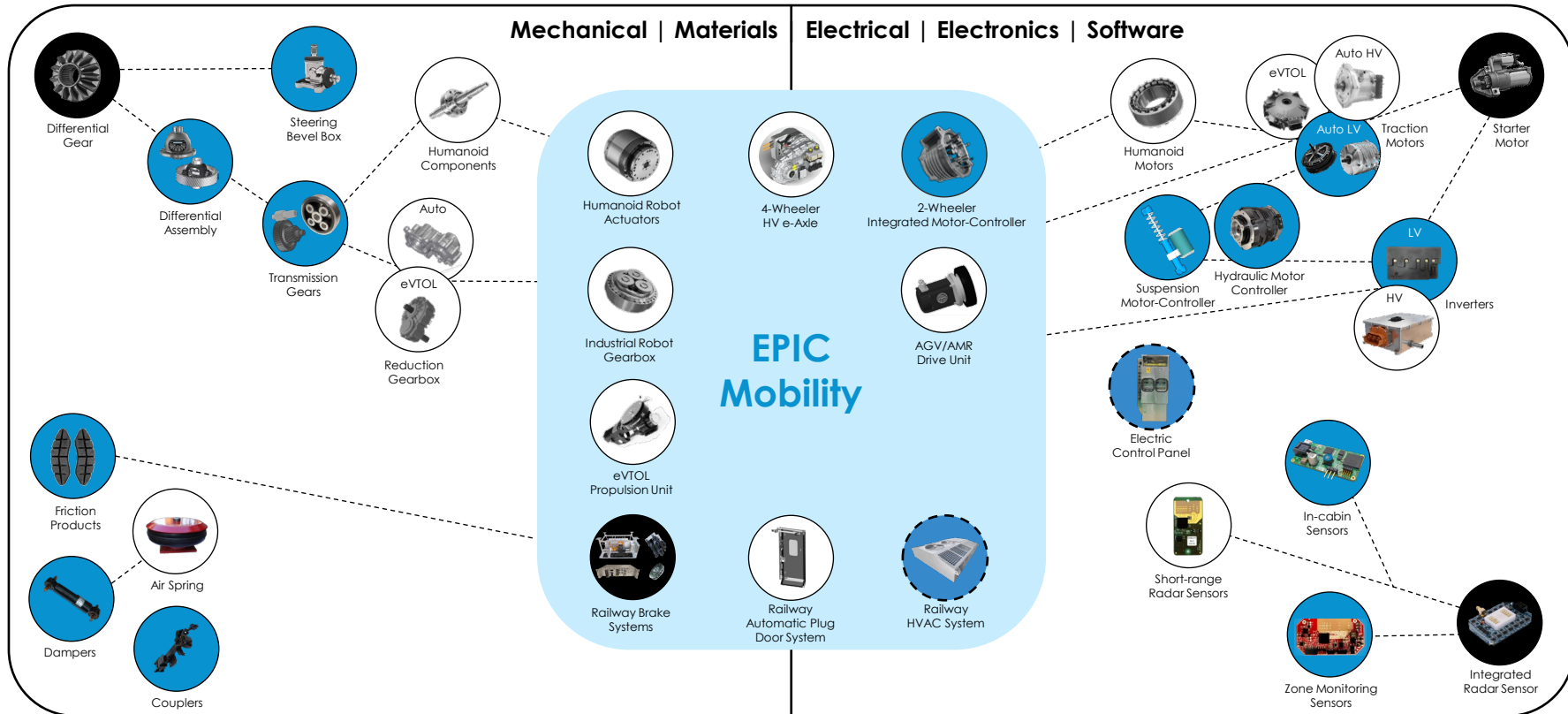

Legacy Products
 Current Products
 Future Products
 Product commercialized in Q4FY26

Note: The product images shown are for illustration purposes only and may not be an exact representation of the products

Q4 & FY26 Financial Update



Our Exhibition Booth at Indian Railway Equipment Exhibition (IREE) 2025

Q4 FY26 Financials

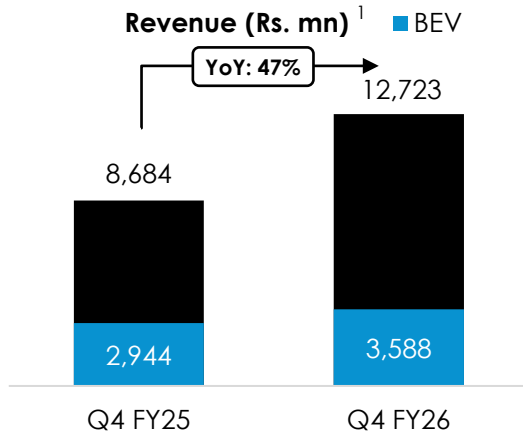

- Our overall revenue grew by 47% during the quarter
- BEV Revenue also grew by 22% and constituted 39% of total automotive product sales

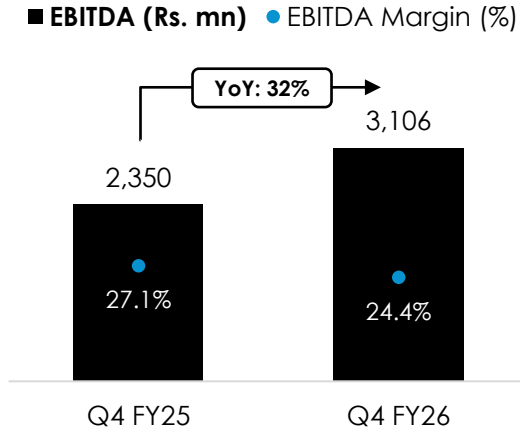

- Our EBITDA grew by 32% while EBITDA margin declined by ~2.7%
 - Q4FY25 EBITDA had full-year PLI income which caused an impact of ~1.9%
 - Balance ~0.8% impact from product mix and commodity inflation

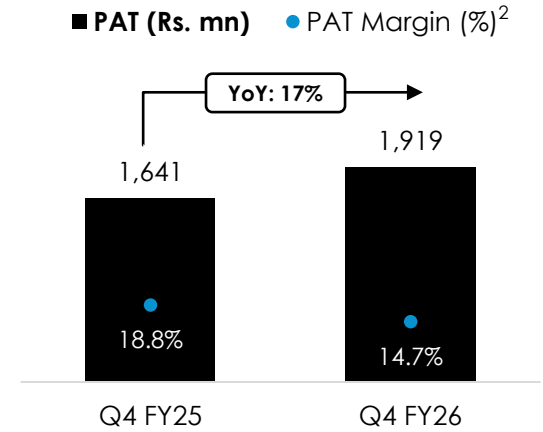

- PAT margin is lower by ~4.1% due to
 - Effect of lower EBITDA margin ~2.0%
 - lower net finance income ~3.4%
 - Net positive impact of lower depreciation and higher tax ~1.3%

Notes:

1. Revenue includes net gain from foreign exchange
2. PAT margin percentage calculated from PAT including non-controlling interest

FY26 Financials

Revenue (Rs. mn)¹ ■ BEV

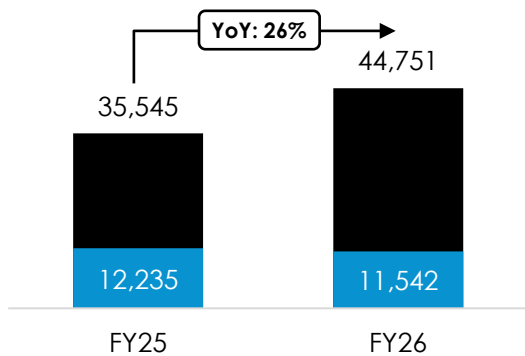

- Our overall revenue grew by 26% during the year
- BEV Revenue declined by 6% and constituted 35% of total automotive product sales

■ EBITDA (Rs. mn) ● EBITDA Margin (%)

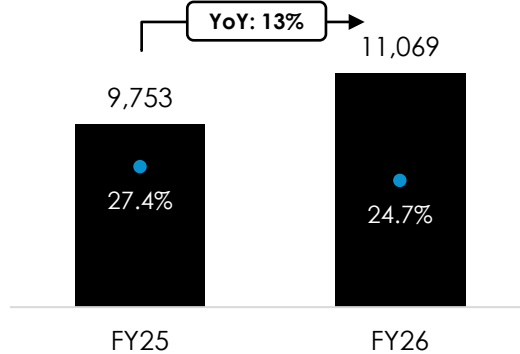

- EBITDA margin is lower by ~2.7% largely due to adverse product mix and increase in fixed cost

■ PAT (Rs. mn) ● PAT Margin (%)²

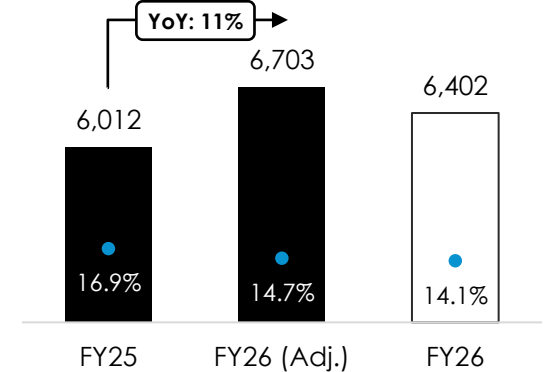

- FY26 PAT has a one-time impact of ₹301 mn due to the new labour code
- PAT margin adjusted for the above is lower by ~2.2% mainly due to transmission of lower EBITDA margin and lower net finance income

Notes:

1. Revenue includes net gain from foreign exchange
2. PAT margin percentage calculated from PAT including non-controlling interest

FCFO of INR 2,900 mn in FY26

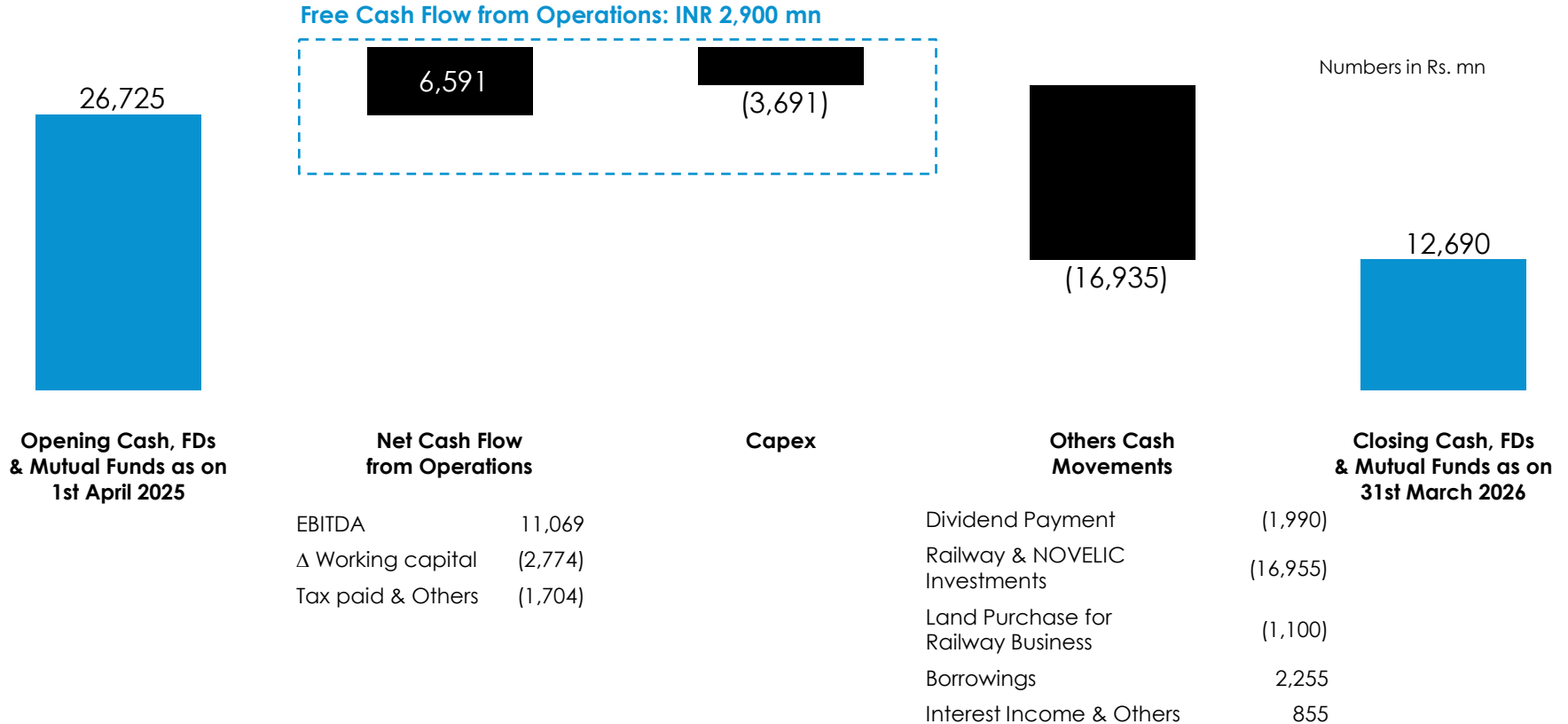

Key Ratios

VA/Employee cost

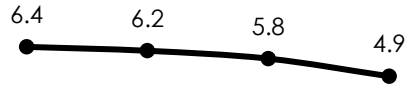

Mar-23 Mar-24 Mar-25 Mar-26

RoCE (%)

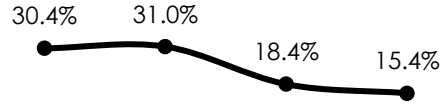

Mar-23 Mar-24 Mar-25 Mar-26

RoE (%)

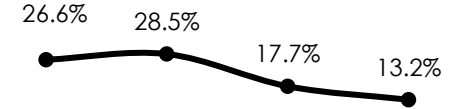

Mar-23 Mar-24 Mar-25 Mar-26

Net Debt to EBITDA

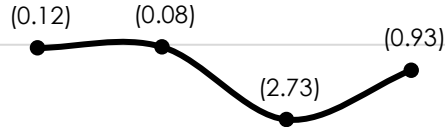

Mar-23 Mar-24 Mar-25 Mar-26

Working Capital Turnover

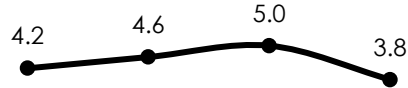

Mar-23 Mar-24 Mar-25 Mar-26

Fixed Asset Turnover



Mar-23 Mar-24 Mar-25 Mar-26

Note:

- 1) VA/Employee Cost (for manufacturing businesses only) = Material margin / (Employee cost + Manpower cost on hiring)
- 2) ROCE = LTM EBIT/(Average tangible capital employed + capital deployed for acquiring NOVELIC and Railway Business)
- 3) ROE = LTM PAT/(Average tangible net worth + capital deployed for acquiring NOVELIC and Railway Business); LTM PAT is adjusted for one-time impact of ₹301 mn due to the new labour code
- 4) Net Debt to EBITDA = Short-term & long-term debt less cash, bank balances & mutual fund investments / LTM EBITDA
- 5) Working Capital Turnover (WCTR) = LTM Revenue/ Average net working capital
- 6) Fixed asset turnover (FATR) (for manufacturing businesses only) = LTM Revenue/ Average Tangible net block
- 7) ROCE, WCTR and FATR have been normalized by annualizing Railway Business EBIT and turnover respectively



SONA COMSTAR



NOVELIC

MOVING MOBILITY FORWARD.

ELECTRIC. PERSONALIZED. INTELLIGENT. CONNECTED.
DRIVELINE | MOTOR | RAILWAY | SENSOR



Q&A

Demonstration of our AMR Platform at Consumer Electronics Show 2026

Appendix

Our Chairman Emeritus addressing the stakeholders on our 25th anniversary celebration



Our story so far...

Phase - 1

- 18 Customers
- 2 Plants
- 1 Product

Phase - 2

- 22 Customers
- 2 Plants
- 2 Products

Phase - 3

- Acquisition of Comstar
- 47 Customers (37+10)
- 9 Plants (5+4)
- 10 Products (5+5)

Phase - 4

- Became publicly listed
- Acquisition of NOVELIC and Railway Business
- 12 plants
- 29 products

Revenue in INR millions

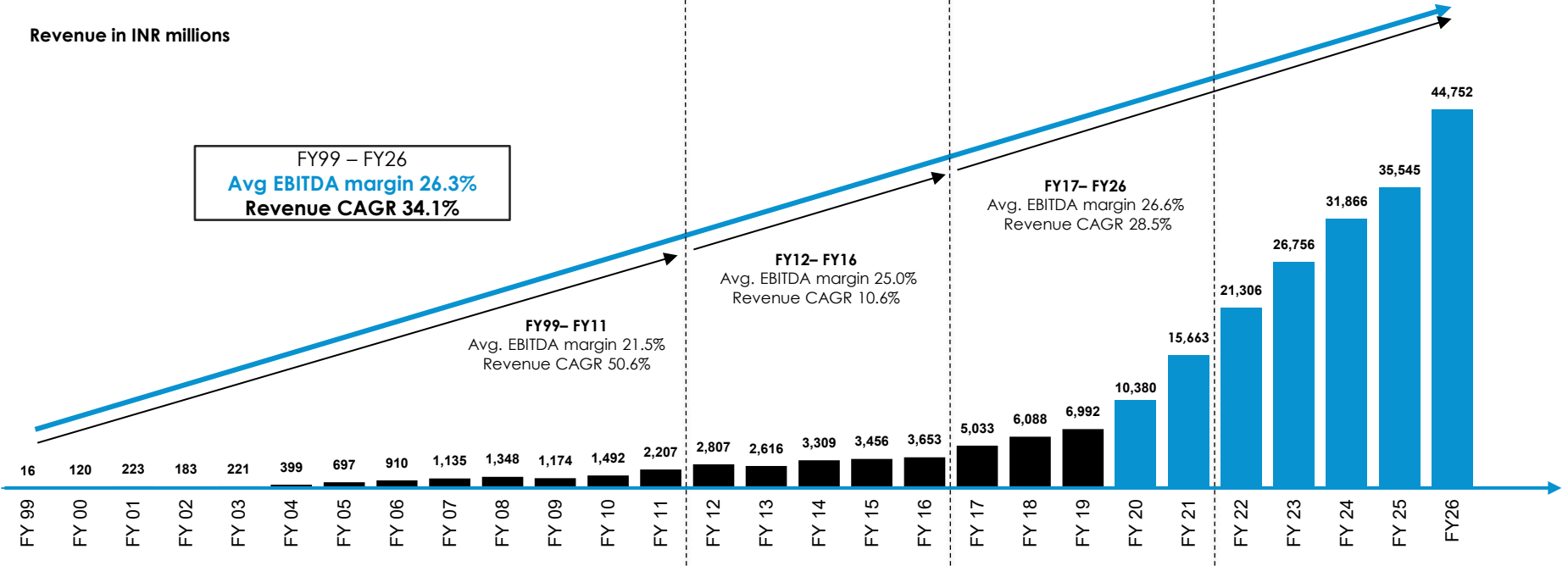

One Vision

To become one of the World's
most **Respected** and **Valuable**
Mobility Technology
companies for our
Customers, Employees &
Shareholders

Guided by Values

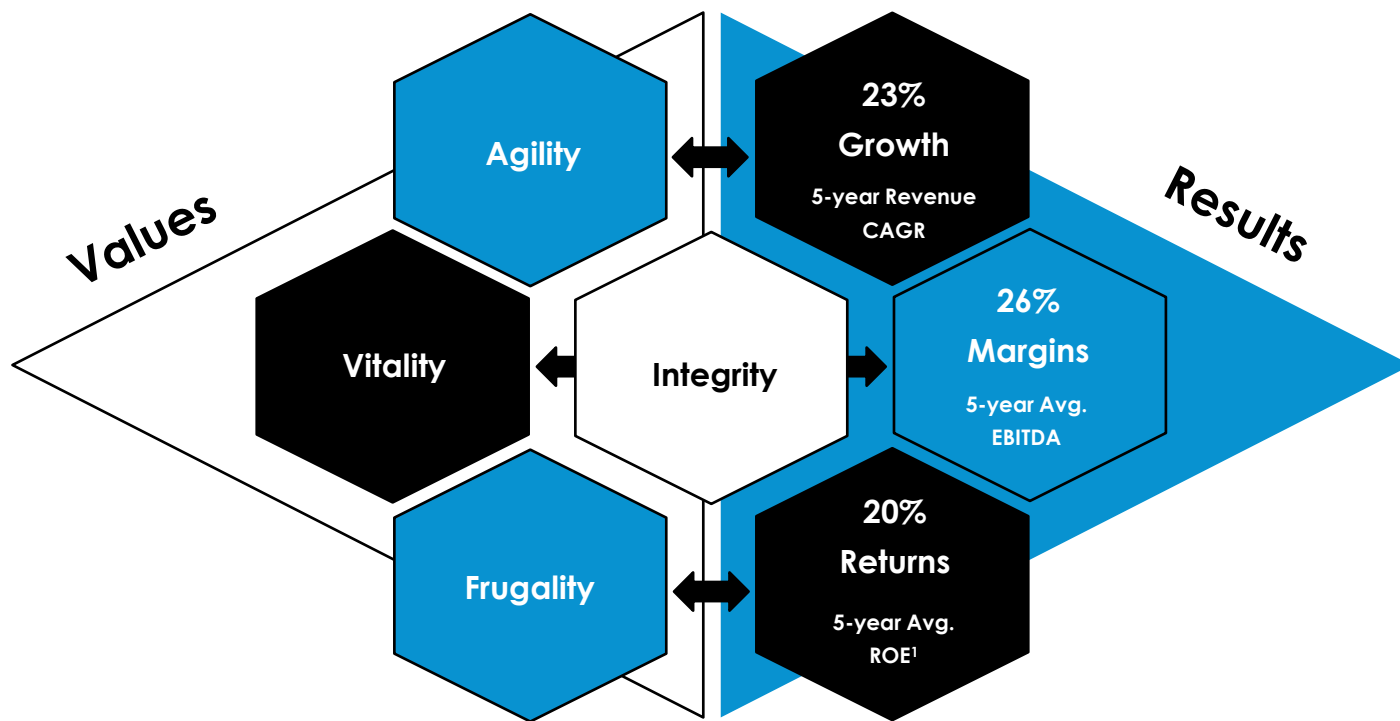

Note:

1) ROE = 5-year average of PAT/5-year average of (Average tangible net worth + capital deployed for acquiring NOVELIC and Railway Business); For a 5-year period of FY22 to FY26

Established Global Presence to Serve Customers Locally

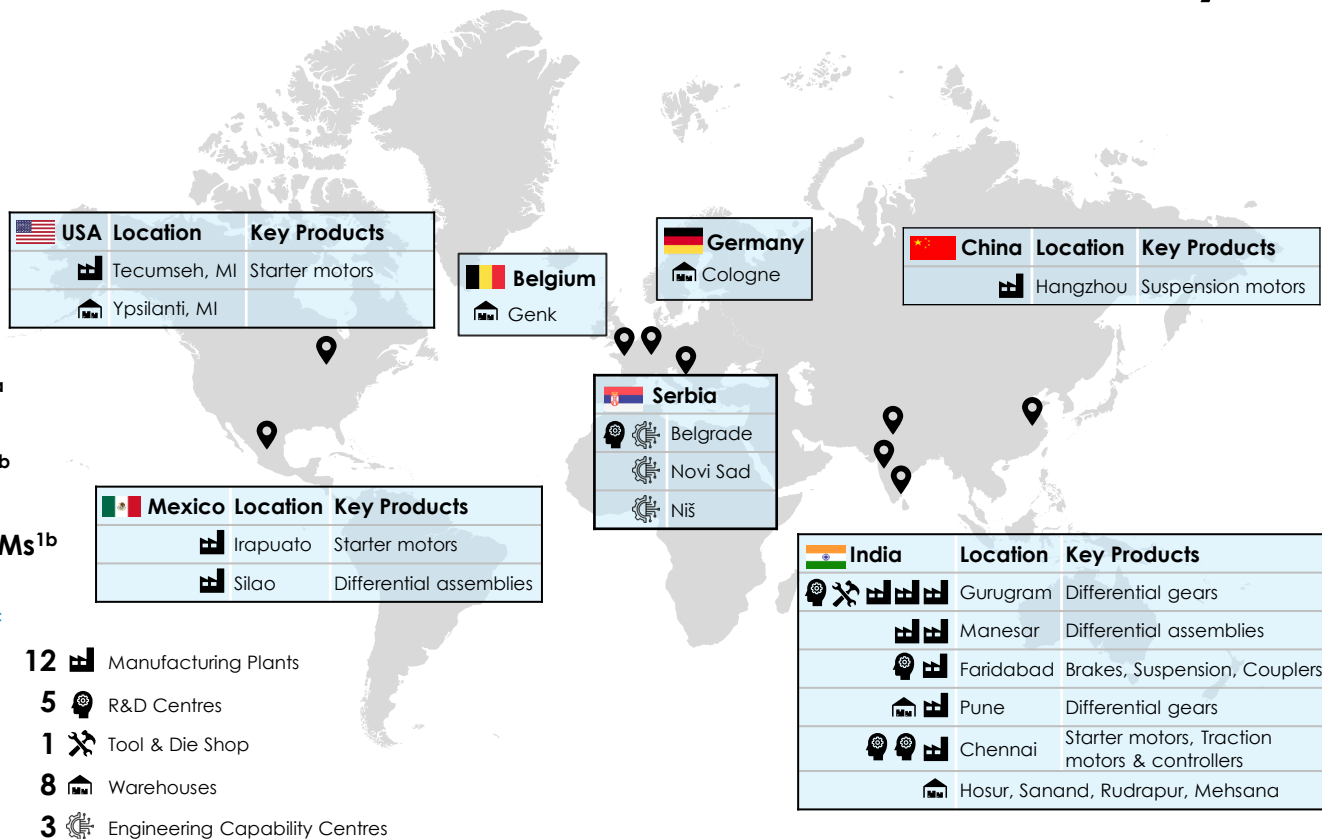

- 7 of the world's top 10 PV OEMs^{1a}
- 3 of the world's top 10 CV OEMs^{1b}
- 7 of the world's top 10 tractor OEMs^{1b}
- 3 of the world's top 10 EV OEMs^{1c}
- 3 of the Indian top 10 Indian e-2-Wheeler OEMs^{1d}

Notes:

1. Data Source: a) BofA Global Automobiles Report; b) Ricardo Report; c) EV-Volumes; d) Vahan Database; Company Analysis

BEV revenue and BEV revenue share¹ over the years

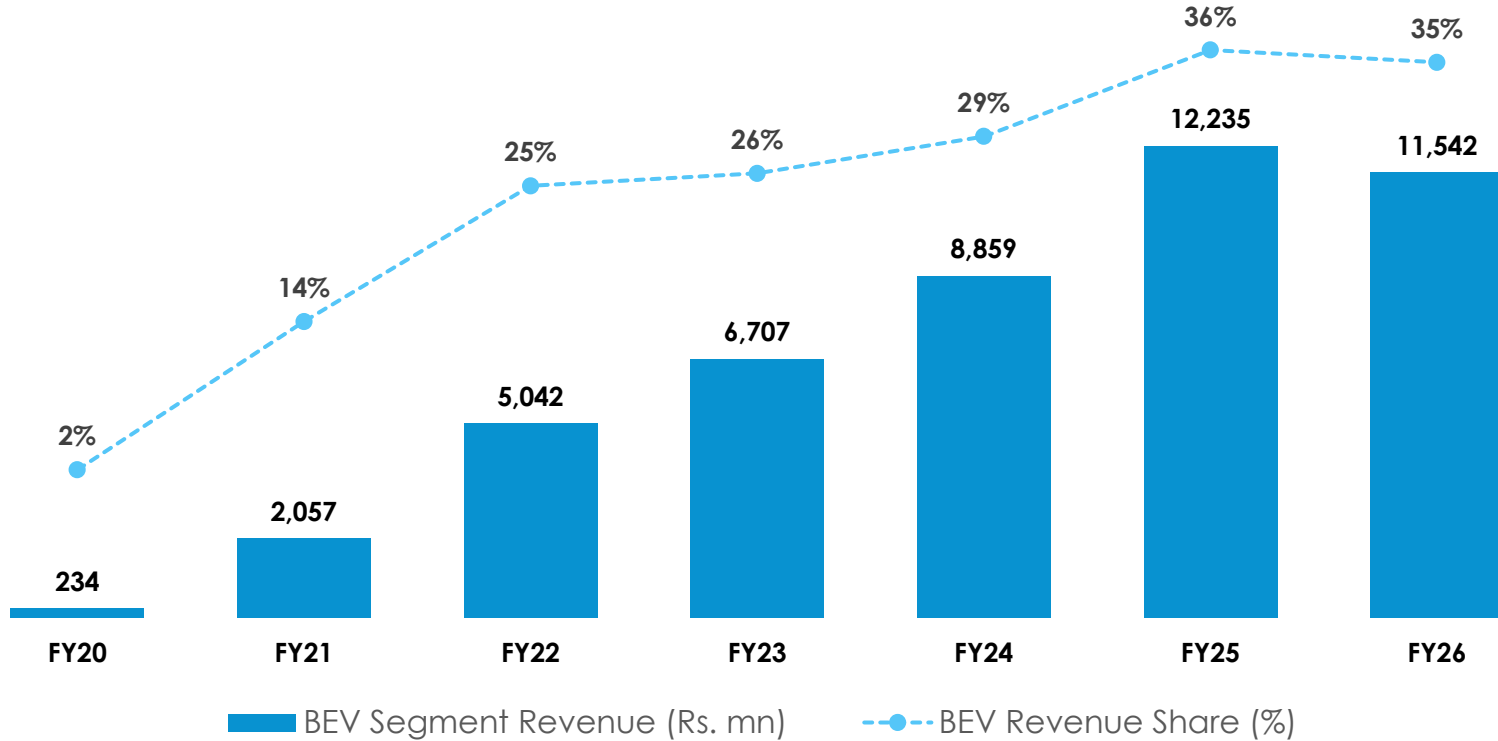

Notes:

1. Includes product revenue from PV, CV, OHV, E2W, E3W vehicle segments

Diversified Automotive Product Revenue¹ – By Powertrain

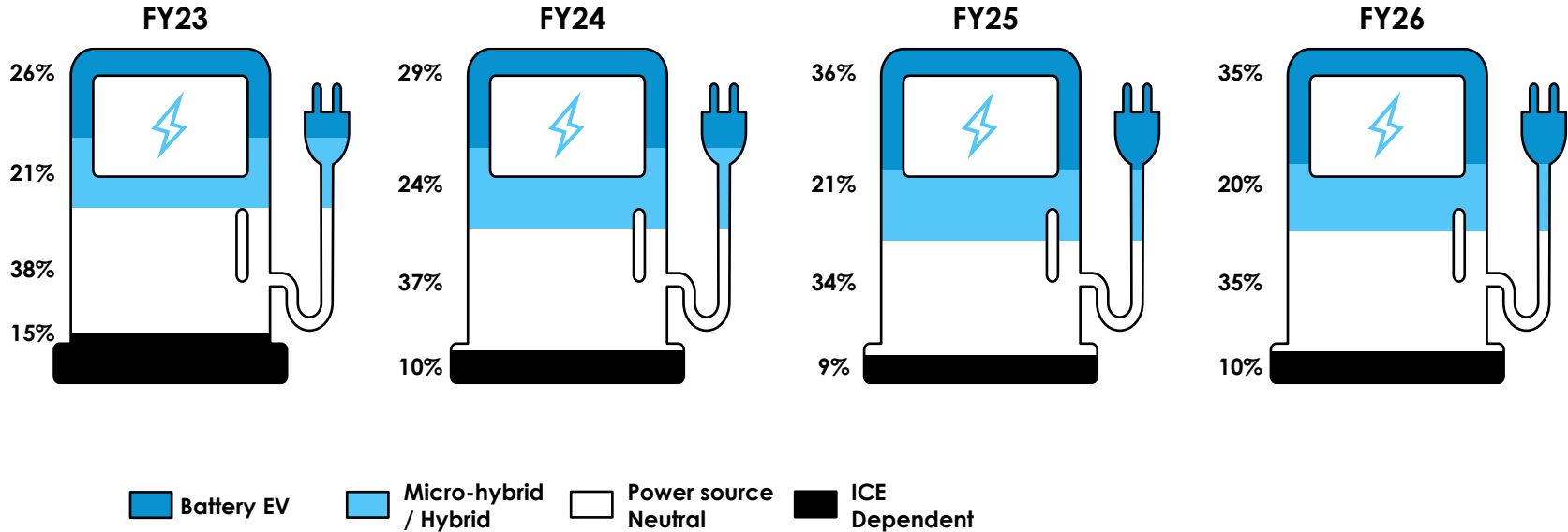

Note:

1. Includes product revenue from PV, CV, OHV, E2W, E3W vehicle segments

67 EV programs across 35 different customers¹



No. of programs customers			
	34 12	3 3	10 8
	3 3	15 10	2 2
	1 1	-	-

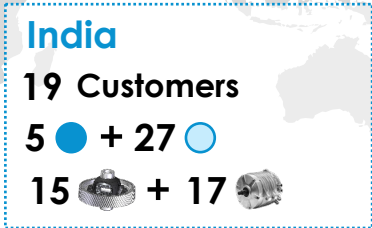
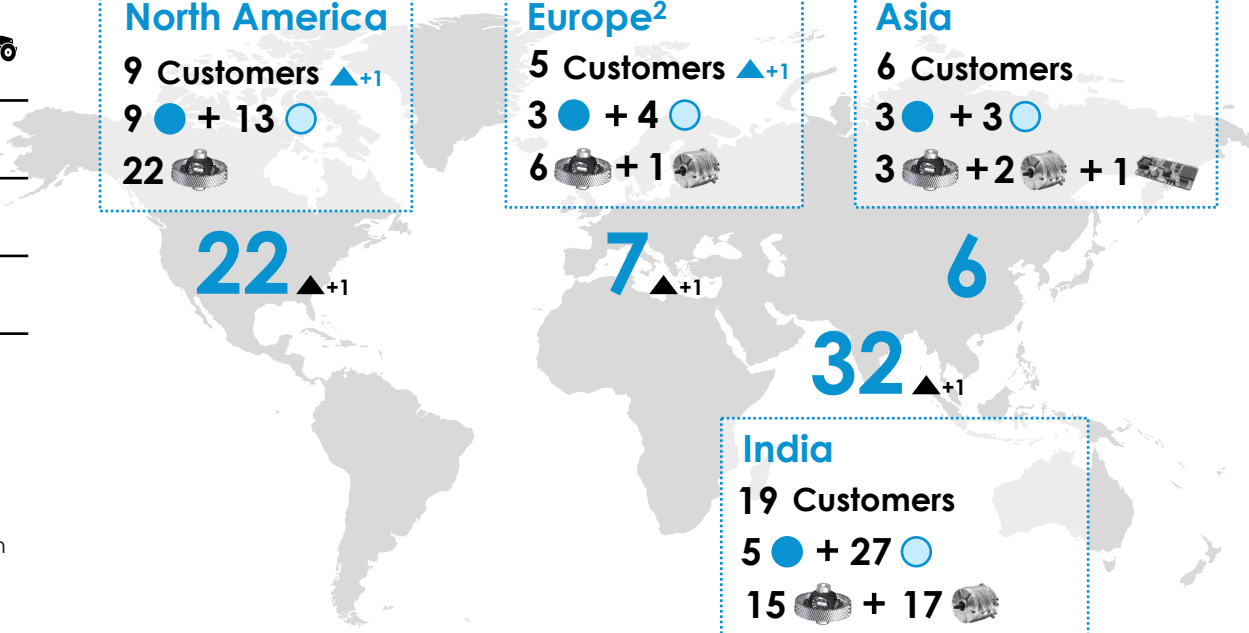
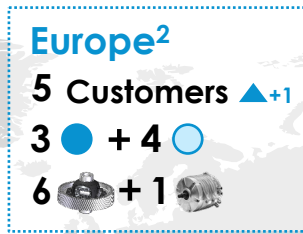
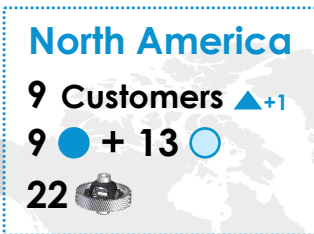

- Programs in fully ramped-up production
- Programs in ramp-up or not yet in production
- Programs for Driveline business
- Programs for Motor business
- Programs for Sensors and Software business

▲+x denotes the change during Q3 FY26

Notes:
 1. 3 customers are present in more than one geography
 2. Europe geography includes the UK

Market Shares for Differential Gears and Starter Motors

Global Market Share of Differential Gears¹

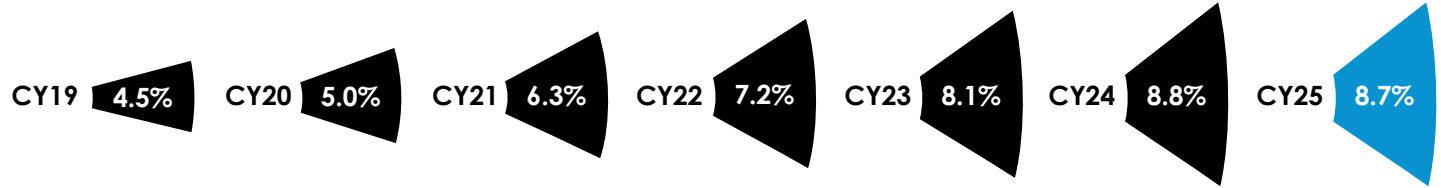

Global Market Share of Starter Motors¹



Passenger Vehicles



55-60%²

Commercial Vehicles



80-90%²

Tractors



75-85%²

While we dominate the Indian market for Differential Gears

Notes:

1. Data Source: Ricardo, CRISIL, Company Analysis
2. As per CRISIL report dated Feb 2021

Product Summary

Passenger Vehicles

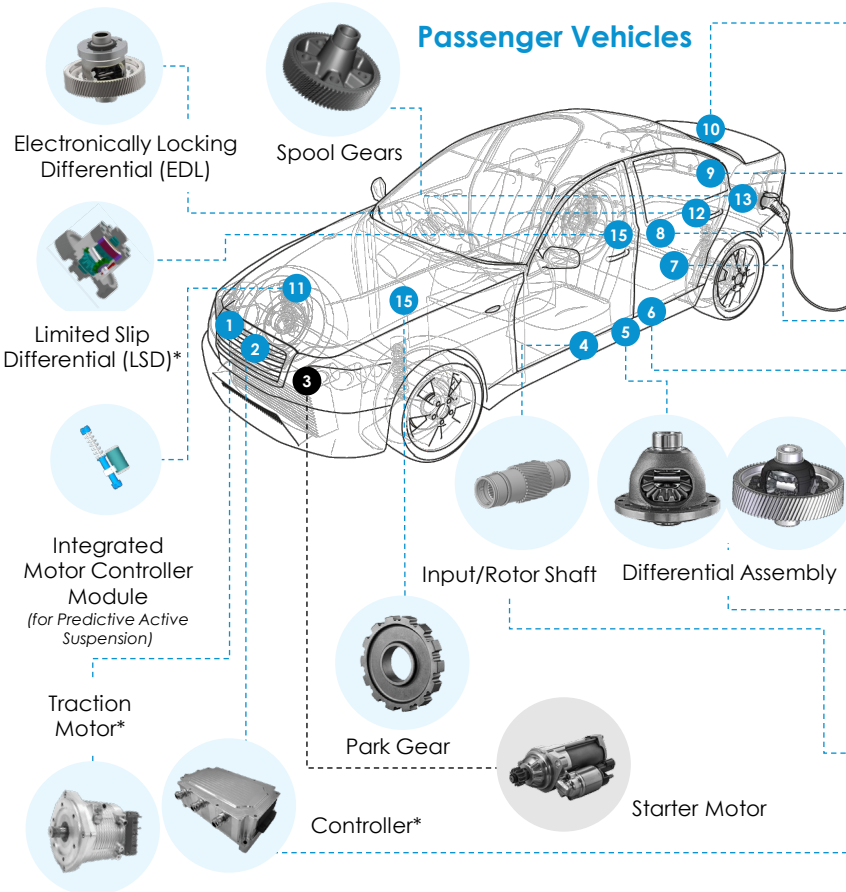

Electronically Locking Differential (EDL)



Spool Gears



Limited Slip Differential (LSD)*



Integrated Motor Controller Module
(for Predictive Active Suspension)



Traction Motor*

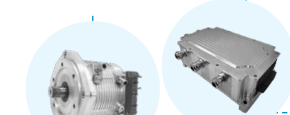

Controller*



Input/Rotor Shaft



Differential Assembly



Differential Bevel Gears



Park Gear



Starter Motor

Commercial Vehicles

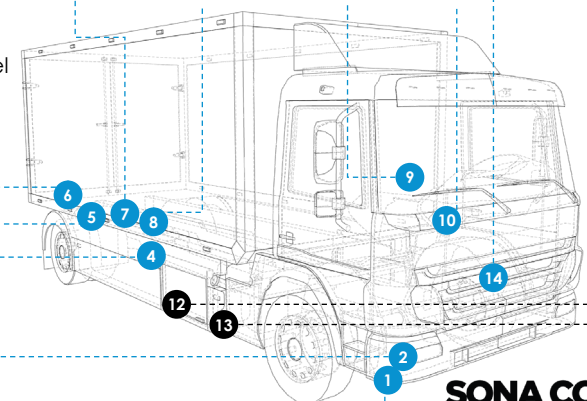

Epicyclic Geartrain



Intermediate Gears



In-Cabin Radar Sensors



Short Range Radar Sensors*



Steering Bevel Box



Coupling/Sleeves

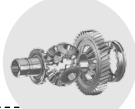

Inter-Axle Gear Set

*Product under development

Product Summary

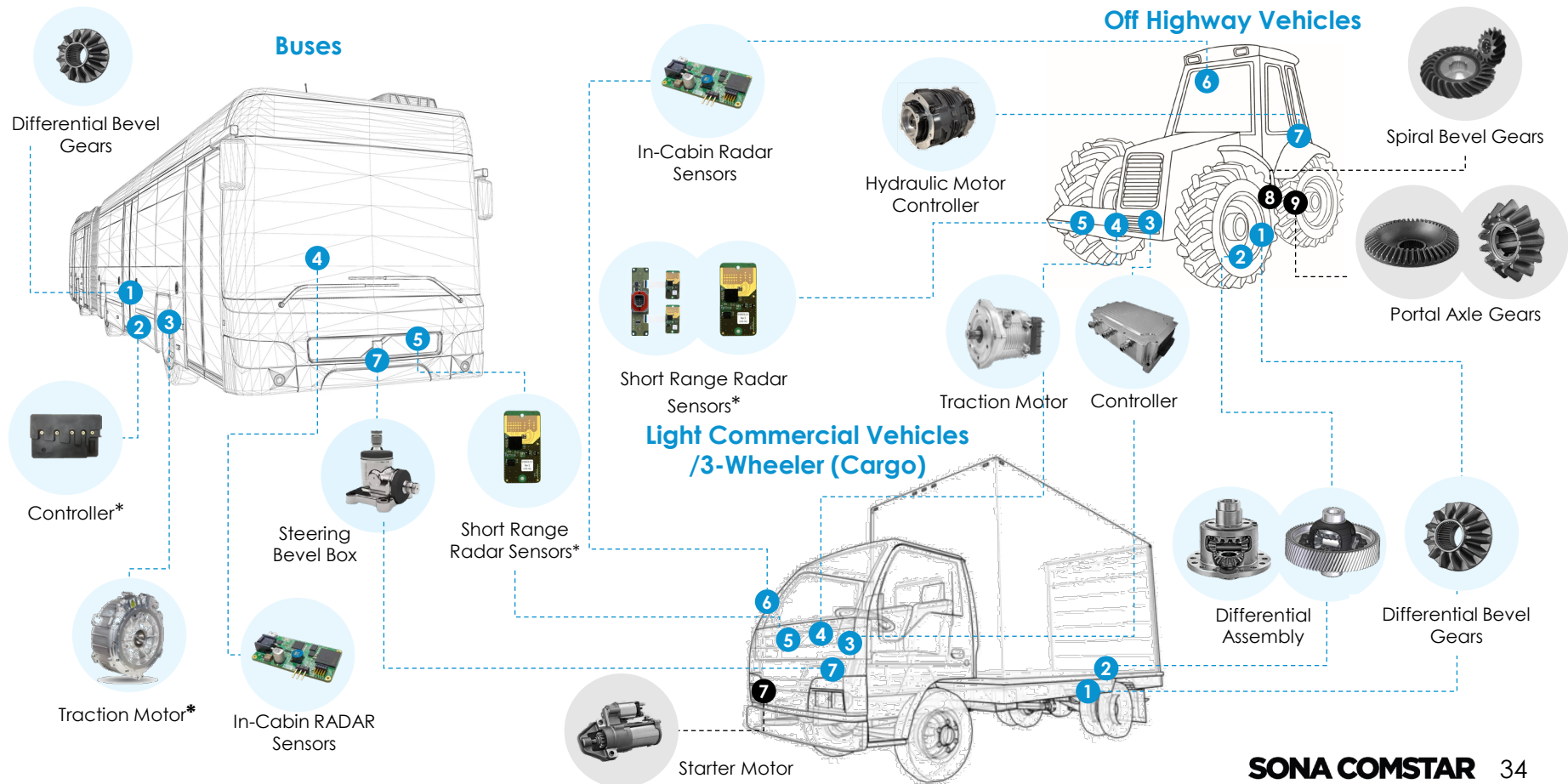

*Product under development

Product Summary

Electric 2-Wheelers

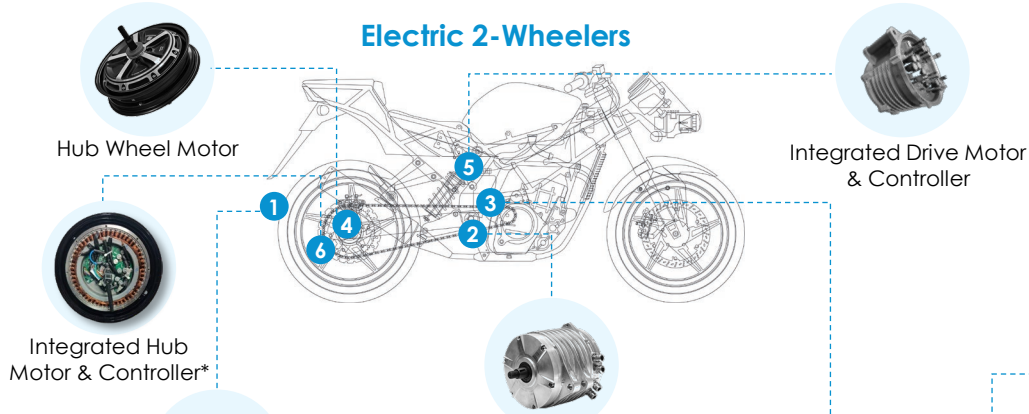

Electric 3-Wheelers

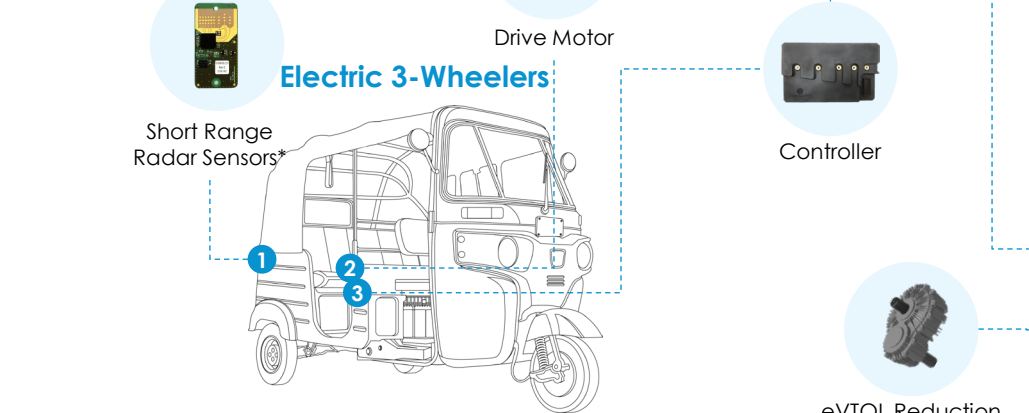

Non-Automotive

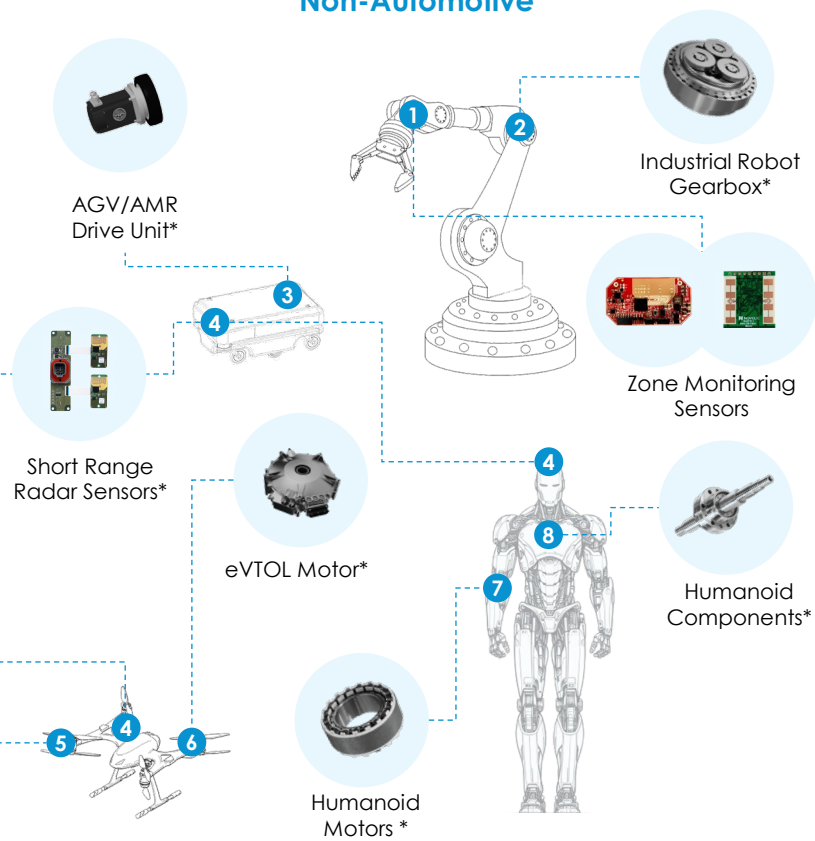

*Product under development

Product Summary

Railways

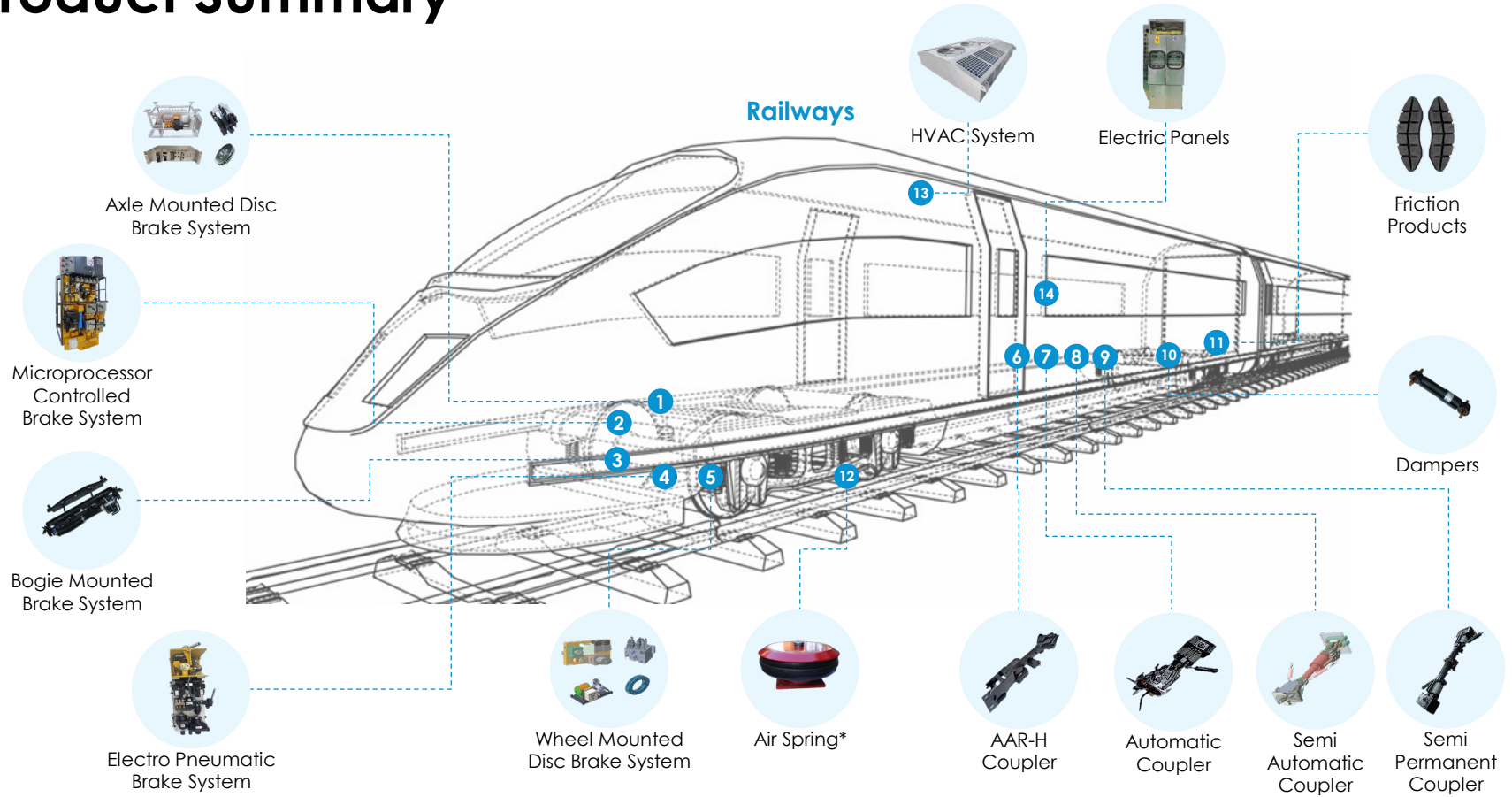

*Product under development

ESG Performance Highlights



- 18%, 17%, and 10% improvement in emissions, water, and energy intensities respectively, in FY25 from FY22
 - Setting up a total solar group captive capacity of 21.35 MWp across Maharashtra, Haryana, and Tamil Nadu
 - Pune Chakan Plant has been rated by IGBC in the Green Factory Building category with "IGBC Gold" Rating
 - Initiated a large-scale afforestation project by planting more than 46k trees using the Miyawaki method
-



- Have been certified as Great Place to Work consistently for last three years
 - Driving incubation of 18 startups innovating for sustainability in partnership with IIT Delhi and IIM Ahmedabad
 - Improved the female participation in the total workforce from 3% to 6%
 - Achieved reduction of 98% in CO levels at Gurgaon plant using a three-stage air purification approach
-



- Golden Peacock Award won in 2023 for excellence in corporate governance
- Award for Excellence in Corporate Governance' by the Institute of Company Secretaries of India (ICSI)
- 6 independent directors and 3 women directors out of 9 board members
- Chairperson position is held by an independent director