



Date: March 06, 2025

**The National Stock Exchange of India
Limited**
Exchange Plaza, Bandra-Kurla Complex
Bandra (East), Mumbai- 400 051
Symbol: RACLGear

The Bombay Stock Exchange Limited (BSE)
25th Floor, Phiroze Jeejeebhoy Towers
Dalal Street, Mumbai-400 001
Scrip Code: 520073

Subject: Investor Conference Call and Investor Presentation

Dear Sir/Madam,

Pursuant to Regulation 30 of the SEBI (Listing Obligations and Disclosure Requirements) Regulations, 2015, it is hereby informed that the Company conducted an Investor Conference Call on 06th March, 2025. The Investor Presentation for the same is annexed herewith. The Audio Recording of the Conference Call has been placed on the Website of the Company at www.raclgeartech.com.

This is for your information and record please.

Thanking You,

For RACL Geartech Limited

Neha Bahal
Company Secretary and Compliance Officer

Registered Office

15th Floor, Eros Corporate Tower, Nehru Place, New Delhi-110019, INDIA

Phone: +91-11-66155129

CIN: L34300DL1983PLC016136

D-U-N-S Number: 65-013-7086



TS 16949 : 2009
TS 518901 - 000



RACL Geartech Limited

Putting the world to motion



Investor Interaction

Q3 FY 2024-25

Established

1983
New Delhi
DUNS 65-013-7086



Business Highlights

FY24 Revenue
INR 4.23 billion (USD 50.12 million)
804 employees



Product Application

Two Wheelers, Three Wheelers, Passenger Cars, Commercial Trucks, ATV's, Agricultural Equipment, Industrial Gears

22 Active Customers ; **900+** SKU's

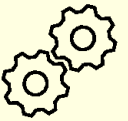

Headquartered in, Noida, India



Company Infrastructure

2 Manufacturing Locations
1 Corporate Office
3 Warehouses in Europe



Product Range

Transmission gears and shafts, sub- assemblies, Precision machined parts, Chassis Parts and Industrial Gears



Financial Outlook

A- Credit Rating
BSE & NSE Public Listed Co
1 Austrian Subsidiary



Core Competencies

Gear Cutting, Precision Machining, Aluminium Machining, Process R&D & Concurrent engineering, Heat Treatment, sub-assembly, Laser Welding & Laser Cutting, Exports Logistics Handling



Company Certifications

ISO 9001	TISAX Rating- 2.8
ISO 14001	Permanent Label
IATF 16949	ISO 27001:2013
ISO 45001;2018	ISO/IEC 17205: 2017



FINANCIAL PERFORMANCE

QUARTERLY RESULTS (Q3 FY24-25)



TOTAL STANDALONE REVENUE FOR Q3 FY24-25

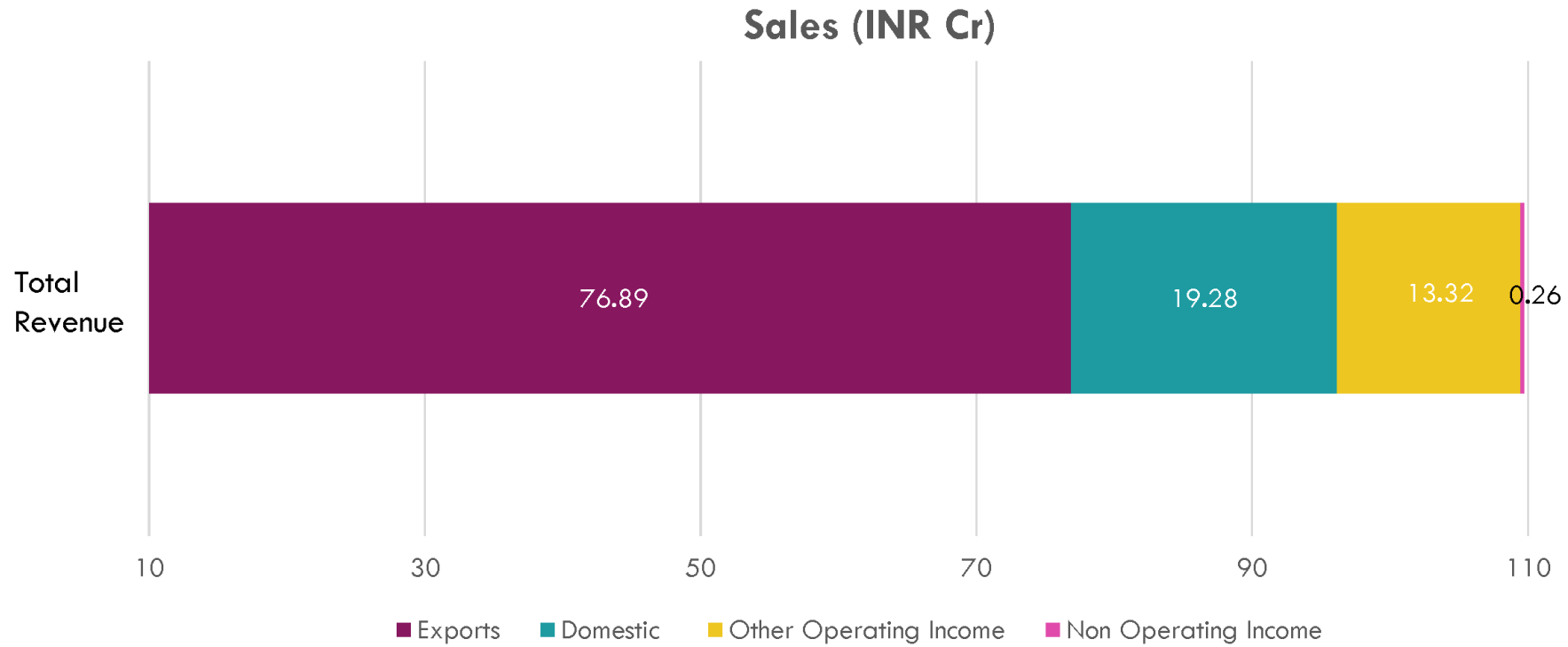

TOTAL SALES: 109.75 CRORE

Sales Segment

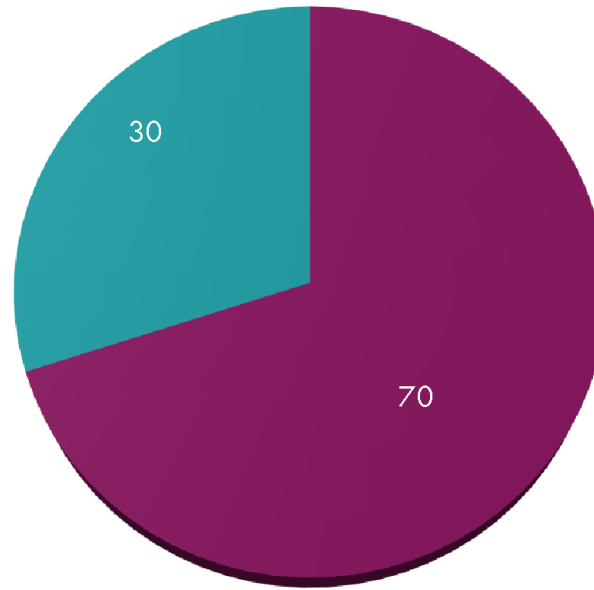

■ Exports ■ Domestic

STANDALONE Q1 VS Q2 VS Q3 SALES & PROFITABILITY FY 24-25

Sales (INR Cr)

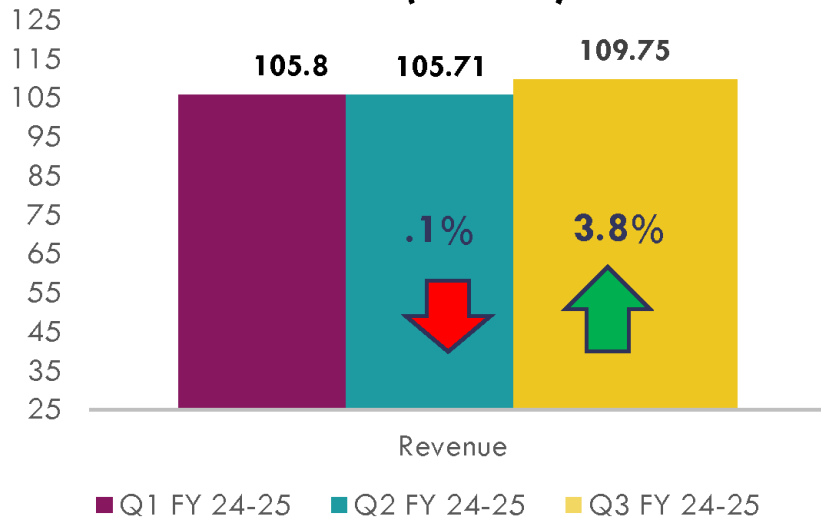

EBITDA (INR Cr)

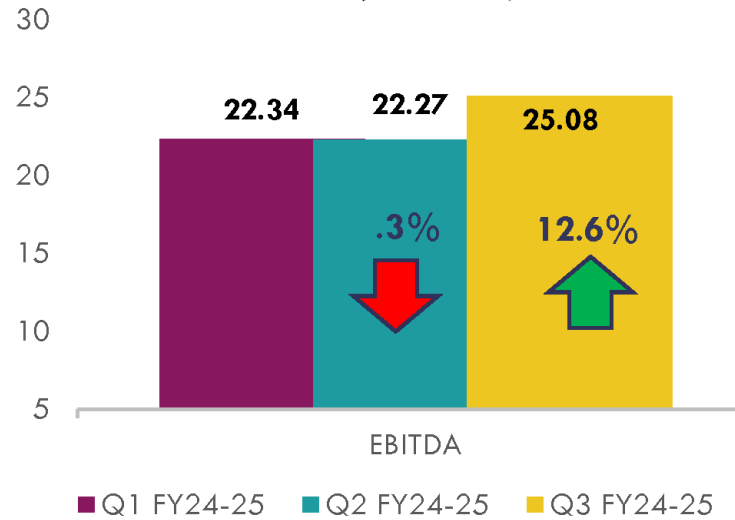

PBT (INR Cr)

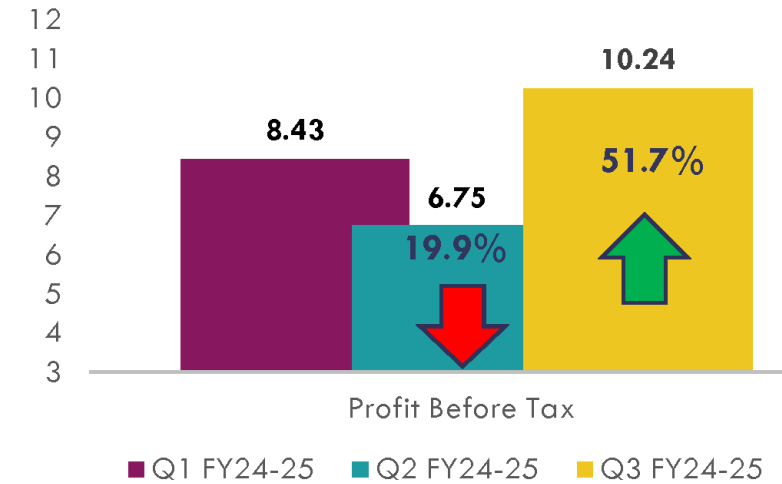

NINE MONTHLY PERFORMANCE SALES & PROFITABILITY FY 24-25

YoY Sales (INR Cr)

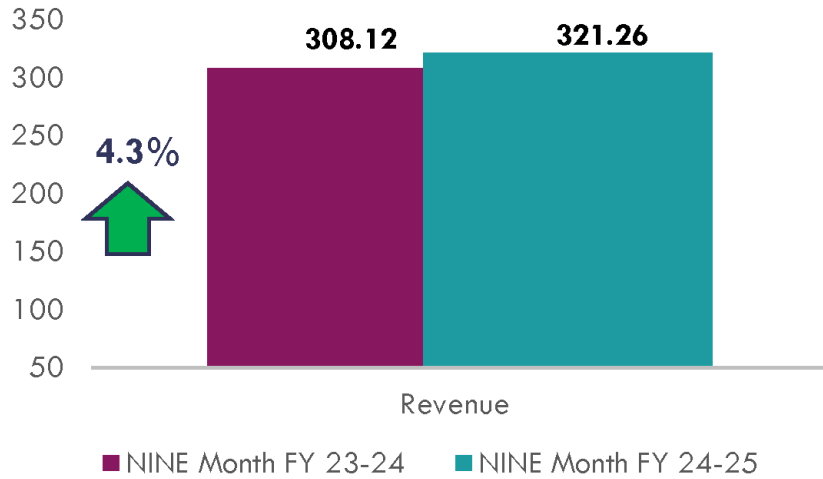

YoY EBITDA (INR Cr)

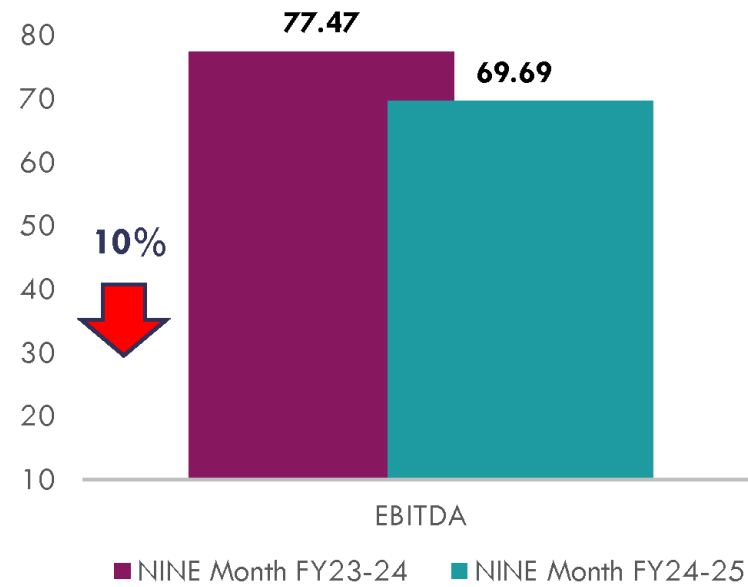

YoY PBT (INR Cr)

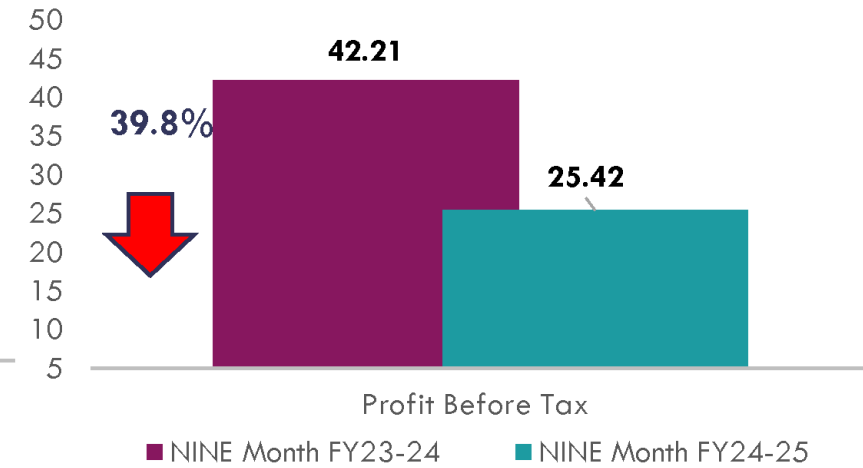

YoY Sales (INR Cr)

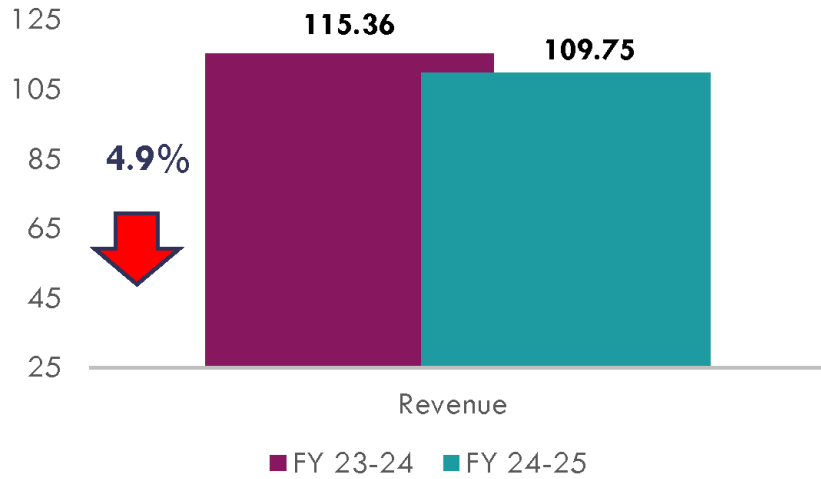

YoY EBITDA (INR Cr)

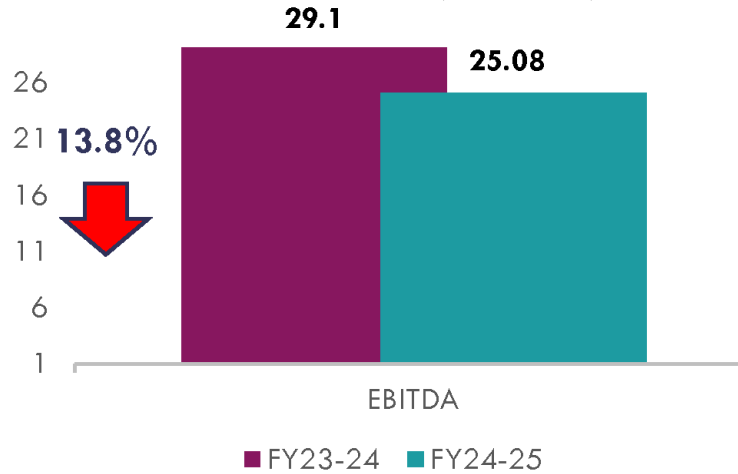

YoY PBT (INR Cr)

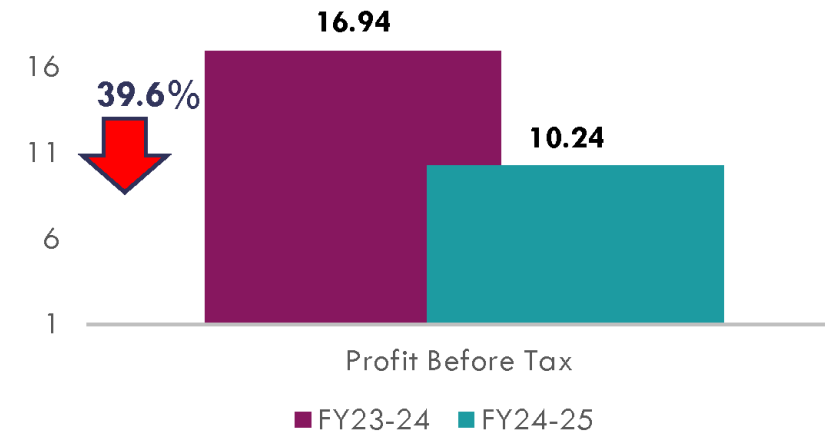

PROFITABILITY COMPARISON

Breakup Of Decline In EBITDA	From Q3 23-24	From 9M 23-24
Consumption Raw Material	1.10%	0.73%
Employee Benefit Expense	1.21%	0.63%
Total Finance Cost	1.29%	1.46%
Depreciation	1.69%	0.88%
Total Manufacturing Expenses	-0.63%	1.40%
Total Administration, Selling & Other Expenses	0.68%	0.70%
PBT Difference	-5.35%	-5.79%
EBITDA Difference	-2.37%	-3.45%

Period	Q3 24-25	Q2 24-25	Q1 24-25	FY 23-24	FY 22-23
EBITDA % Of Sales	22.86%	21.06%	21.11%	24.09%	24.69%



UPDATES

Business Updates

As on November 29, 2024, KTM has initiated **judicial restructuring proceedings** under self-administration, allowing the company 90 days to negotiate new debt financing terms with creditors before potentially entering formal insolvency proceedings.

Highlights of the same as below:

- Creditors to receive cash quota of 30 % of their claims as one off payment and accordingly KTM AG to deposit an amount of EURO 548 Million with the restructuring administrator by May 23, 2025.
- Production to be ramped up again from Mid March 2025 and planned full capacity utilization to be achieved within three months.
- Extended circle of shareholder will provide financial resources totally EURO 50 Million to enable them to commence and ramp up production.



One of the reason was due to a significant buildup of unsold finished motorcycle inventory. This development had a noticeable impact on RACL's Q3 financial performance.

Restructuring plan of KTM AG accepted by the creditors on February 25, 2025.

Given RACL's diversified customer and product portfolio, the impact on its planned growth for FY25/26 remains **minimal**. The company is targeting a revenue budget of INR 525 crore (+/- 5%) for FY25/26.

** All above information related to KTM Group is as per disclosures on their website.*

INAUGURATION OF NEW MANUFACTURING FACILITY

- Official inauguration of our new manufacturing facility named as “UDYAM” for BMW electric car parking lock mechanism took place in the esteemed presence of the BMW AG and BMW IPO team, along with the RACL Management on February 13, 2025.
- This manufacturing facility is now ready for operations and final commercial production will commence as per the timelines previously shared.
- Mass Production is expected to be started in August 2026.



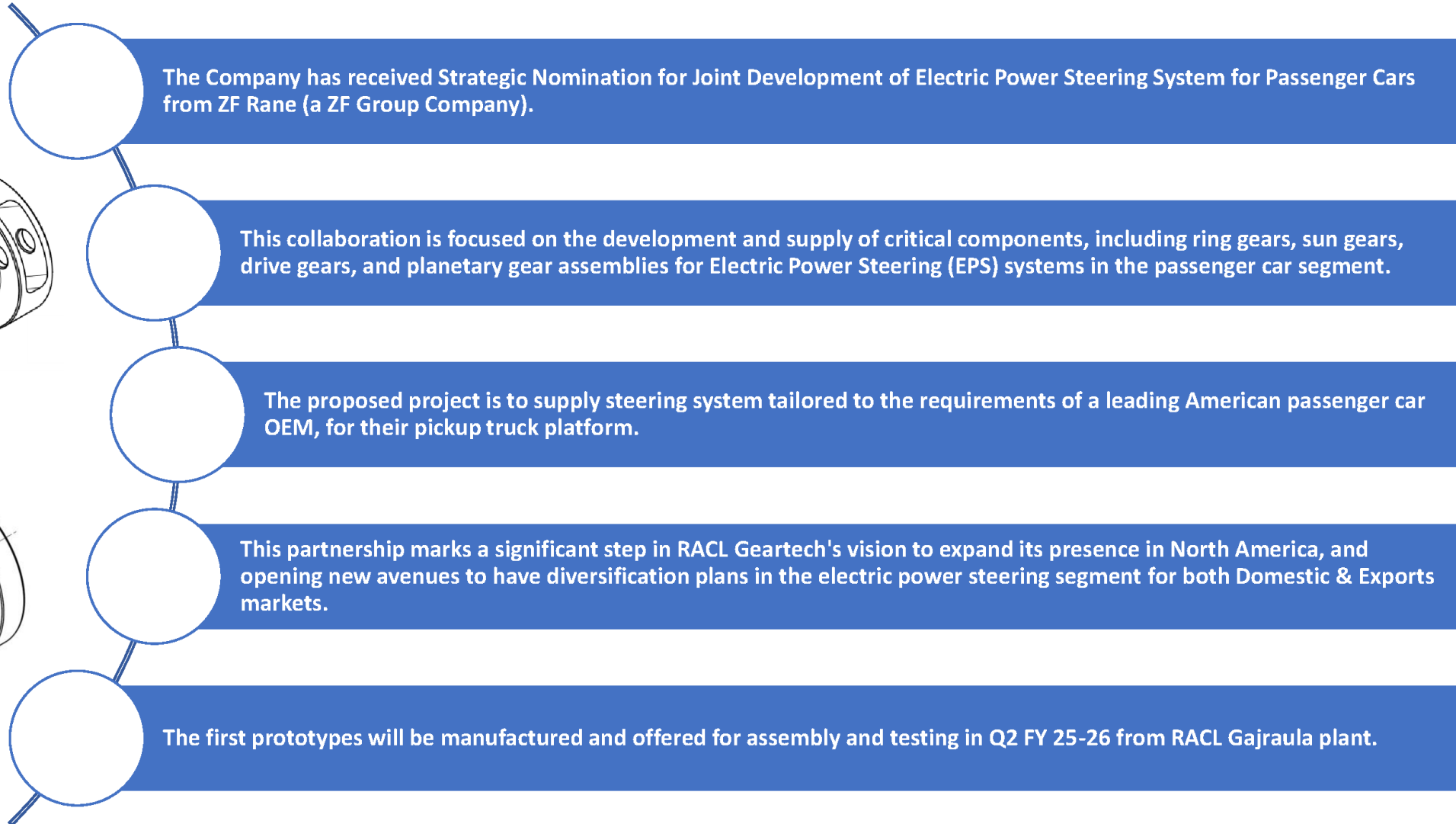
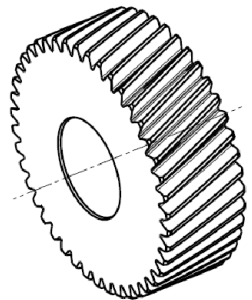
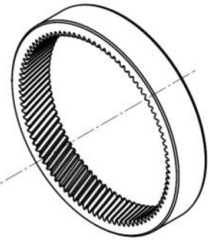
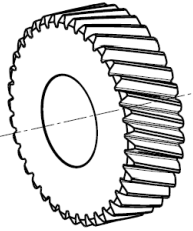
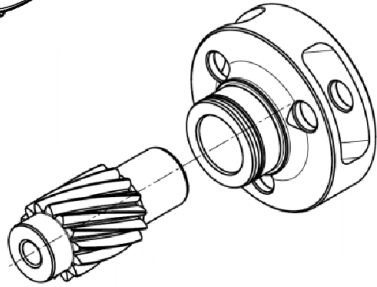
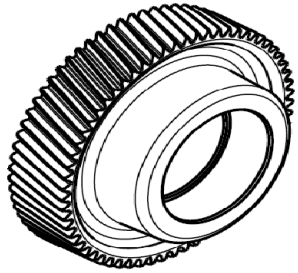

The Company has received Strategic Nomination for Joint Development of Electric Power Steering System for Passenger Cars from ZF Rane (a ZF Group Company).

This collaboration is focused on the development and supply of critical components, including ring gears, sun gears, drive gears, and planetary gear assemblies for Electric Power Steering (EPS) systems in the passenger car segment.

The proposed project is to supply steering system tailored to the requirements of a leading American passenger car OEM, for their pickup truck platform.

This partnership marks a significant step in RACL Geartech's vision to expand its presence in North America, and opening new avenues to have diversification plans in the electric power steering segment for both Domestic & Exports markets.

The first prototypes will be manufactured and offered for assembly and testing in Q2 FY 25-26 from RACL Gajraula plant.

**Representative Pictures*



- RACL has received new nomination from BMW Motorrad for development of shifting mechanism (manual & automatic both) for their upcoming motorcycle model KSx.
- Presently the Project is at proto trial stage for finalizing the design.
- First Function built samples are expected to be dispatched by September, 2025.
- Final Commercial Production is expected to begin by Q3 FY 2026-27.

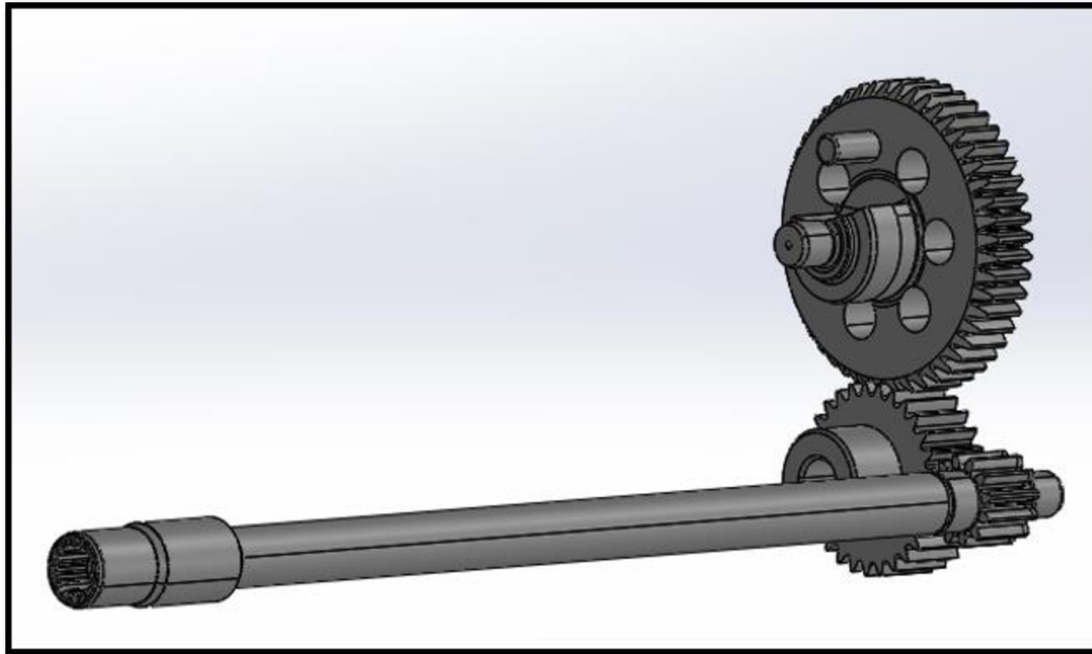

BMW KSx Automatic shifting

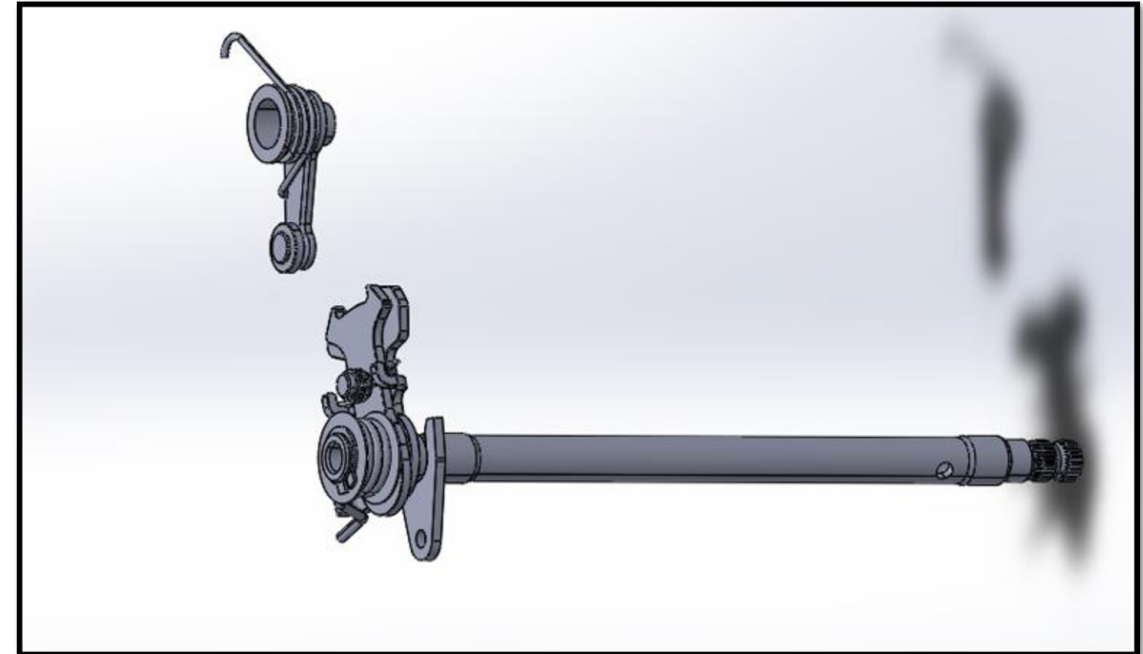

BMW KSx Manual shifting

**Representative Pictures*

NEW NOMINATION FROM TVS NORTON

- TVS had acquired a British premium motorcycle company- Norton.
- Norton Motorcycles is renowned for their classic models and eclectic range of luxury motorcycles.
- RACL has been nominated for supply of the entire drive train for Norton motorcycles.
- Initial Samples have already been dispatched.
- Validation & Testing is expected to commence in Q1 of Financial year 2025-26.
- Final Commercial Production is expected to commence by end of calendar year 2025.

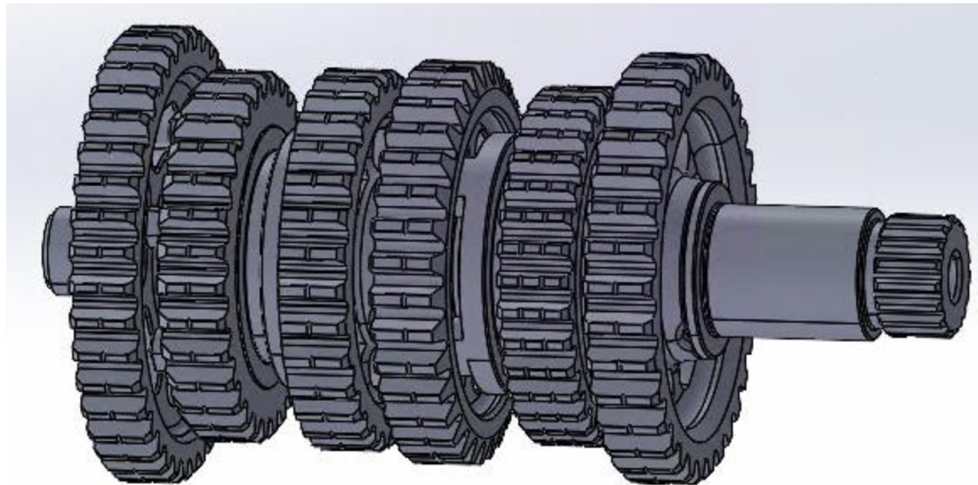
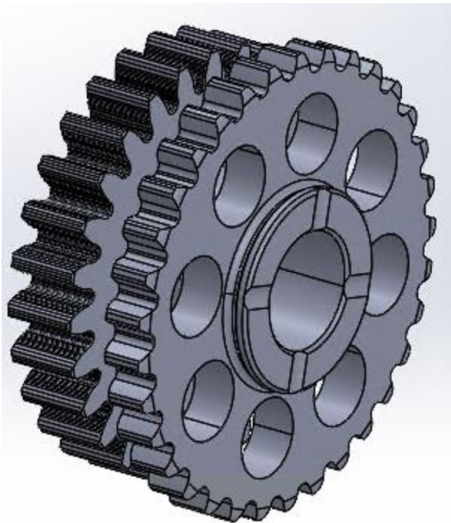

**Representative Pictures*

LISTING ON NATIONAL STOCK EXCHANGE OF INDIA

- The Company has been listed on National Stock Exchange of India on 27th November, 2024 and received listing and trading approval for the same.
- With this, the Company's stock is listed on both recognized leading stock exchanges of India.
- This will help investors of the Company to gain access to more capital, visibility and better transparency and efficiency.
- The Formal Bell Ringing Ceremony at the NSE Mumbai was conducted by Mr. Gursharan Singh, Chairman & Managing Director, along with Mr. Pawan Kumar, one of the longest-serving worker of RACL.
- The daily average trading volume on NSE has increased to more than three times of daily average trading volume on BSE since the date of listing.



1. Renewal Energy Champion:

- Awarded by CII Northern Region Green Practices Awards (3rd Edition)
- Recognized for outstanding efforts and contribution towards renewal energy adoption, sustainable practices and environmental conservation.

2. Gold rating in manufacturing category:

- Awarded by CII- National 5S Excellence Rating (9th Edition)
- Recognition for excellence in manufacturing practices, with an emphasis on cleanliness, organization, and standardization as per the 5S methodology.
- Improved workplace productivity and efficiency through implementation of 5S principles.

3. Recognition for Facilitating Industrial Growth:

- Featured in the January 2025 edition of the UP Invest newsletter, a “Government of UP” Organization
- Acknowledgment for significant contributions to the industrial growth and economic development in the state of Uttar Pradesh

4. NABL Accreditation:

- Awarded for Compliance with ISO/IEC 17205: 2017
- Achieved the prestigious NABL (National Accreditation Board for Testing and Calibration Laboratories) accreditation, validating our adherence to international standards for laboratory testing.

THANK YOU!



RACL Geartech Limited

Registered Office: 15th Floor. Eros Corporate Tower Nehru Place, New Delhi

Corporate Office: B-9 Sector-3, Noida, Uttar Pradesh

Plant 1: A-3 Industrial Area, Gajraula, Amroha

Plant 2: C-32, Sector 80, Noida, Uttar Pradesh

Austria Office: 38, Haufstrasse, 4550, Kremsmunster, Kalsdorf, Upper Austria