



17th November, 2025

The General Manager
The Corporate Relationship Department
BSE Limited
1st floor, New Trading Ring,
Rotunda Building
P J Towers
Dalal Street, Fort
Mumbai 400 001
BSE Scrip Code: 500249

The Manager
Listing Department
National Stock Exchange of India
Limited
“Exchange Plaza”, C-1, Block G
Bandra-Kurla Complex
Bandra (E)
Mumbai 400 051
NSE Symbol: KSB

Subject: Intimation of Presentation for investors meet.

Dear Sir/Madam,

Pursuant to Regulation 30 of the SEBI (Listing Obligations and Disclosure Requirements) Regulations, 2015 please find enclosed herewith the presentation to be presented in the investors meet scheduled to be held on 17th November, 2025.

Please note that the above will be uploaded on the Company's website www.ksbindia.co.in / <https://youtu.be/afRTJvWFW3I>

Kindly take the same on records.

For KSB Limited

Shraddha Kavathekar
Company Secretary

Encl. as above



Solutions. for Life.

INSTITUTIONAL INVESTORS' MEET

17th November 2025

CAUTIONARY STATEMENT

Cautionary Statement Regarding Forward-Looking Statements

This presentation may contain certain forward-looking statements relating to the Company's future business, developments and economic performance.

Such statements may be subject to a number of risks, uncertainties and other important factors, such as but not limited to:

- 1) **Competitive pressures**
- 2) **Legislative and regulatory developments**
- 3) **Global, macroeconomic and political trends**
- 4) **Fluctuations in currency exchange rates and general financial market conditions**
- 5) **Delay or inability in obtaining approvals from authorities**
- 6) **Technical developments**
- 7) **Litigation**
- 8) **Adverse publicity and news coverage**

These could cause actual developments and results to differ materially from the statements made in this presentation. The Company assumes no obligation to update or alter forward-looking statements whether as a result of new information, future events or otherwise.



KSB India – Snapshot

PRESENCE OF KSB IN INDIA

KSB Limited

- Established – 1960
- HQ. – Pune, Maharashtra
- Network –
 - 6 manufacturing plants
 - 6 Service Stations
 - 350+ service centres
 - 22 warehouses



4 zonal offices
14 branch offices
800+ Authorised dealers

KSB Tech Pvt. Ltd.

- Established – 2005
- HQ. – Pune, Maharashtra
- Technology Centre



Bangladesh

- HQ. – Dhaka, Bangladesh
- Liaison Office.

KSB MIL Controls Limited

- Acquired – 1997
- HQ.– Meladoor, Kerala
- 1 Manufacturing Plant – Meladoor, Annamanada, Kerala



KSB India - Manufacturing Facilities



Pimpri, Pune (HQ & Head office, Industrial Pump Division)



Water Pump Division Nashik (Standard Pump)



Shirwal, Satara (Energy Pump Division), 60 km from Pune



Vambori (Foundry Division)

KSB India - Manufacturing Facilities



Coimbatore, (Valves Division)



Chinchwad, Pune
(SupremeServ Division)



Kochi (HQ & Factory MIL)

KSB LIMITED – BOARD OF DIRECTORS



**Mr. Gaurav Swarup,
Chairman**

- ❑ Associated with KSB from FY 2000.
- ❑ A mechanical engineer & MBA from Harvard University.
- ❑ Chairman & MD of Industrial & Prudential Investment Company Limited and other several bodies corporates in and outside India.



**Dr. Stephan Bross,
Non Independent and
Non-executive Director**

- ❑ Associated with KSB from FY 2015.
- ❑ A mechanical engineer, an MBA and holds a doctorate
- ❑ Chief Technology Officer (CTO) of KSB SE & Co. KGaA, Germany
- ❑ Director of several other body corporates



**Dr. Matthias Schmitz,
Non Independent and
Non-executive Director**

- ❑ Associated with KSB Limited from FY 2017.
- ❑ A mechanical engineer, MBA and holds a Doctorate
- ❑ Chief Financial Officer (CFO) at KSB SE & Co. KGaA
- ❑ Director of several other body Corporates



**Mr. Rajeev Jain,
Managing Director**

- ❑ Managing Director of KSB Limited from 2017 .
- ❑ A mechanical engineer and Masters in management sciences
- ❑ Has been holding directorships in several KSB group Companies.

KSB LIMITED – BOARD OF DIRECTORS



**Mr. Ulhas Yargop ,
Independent Director**

- ❑ Associated with KSB since FY 2024
- ❑ B.Tech in Mechanical Engineering (IIT Madras) & MBA (Harvard)
- ❑ 40+ years' experience in Finance, IT, Sustainability, CSR



**Mr. U. C. Muktibodh,
Independent Director**

- ❑ Associated with KSB since FY 2025
- ❑ Expert in Nuclear Power expert; ex-Technical Director, NPCIL
- ❑ B.Tech (Mech) & Master's in Nuclear Engg (BARC)



**Ms. Sharmila Barua
Roychowdhury,
Independent Director**

- ❑ Associated with KSB Limited from FY 2018.
- ❑ A lawyer by profession and holds bachelor's degree in social studies in human behaviour.



**Mr. Vishal Kamapni,
Independent Director**

- ❑ Associated with KSB since FY 2024
- ❑ M.Com & M.Sc (Finance), London Business School
- ❑ Expertise: Investment Banking, Real Estate, Private Equity
- ❑ Director at JM Financial Group

MANAGEMENT TEAM



****Names from Left to Right***

Mr. Nitin Patil
— Vice President IPD & EPD Operations
and Nuclear Business

Mr. Mohan Patil

— Vice President Human Resource

Mr. Rajeev Jain

— Managing Director

Mr. Mahesh Bhawe

— Chief Finance Officer, Vice President

Finance & DTC and Purchase

Mr. Sunil Bapat

— Vice President WPD Operations and Solar

Business

Mr. Prashant Kumar

— Vice President Sales & Marketing

Financial Performance

Financial Snapshot

Employees

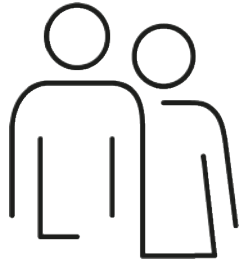

2,206

As on 30th September 2025

Revenue from sales (MINR)

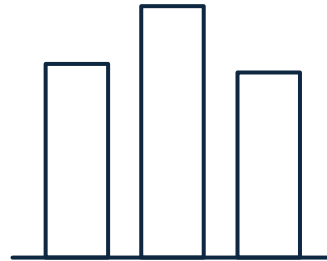

19,117

Nine Months ended
30th September 2025

18,067

Nine Months ended
30th September 2024

Profit Before Tax (MINR)

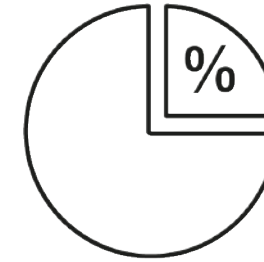

2,485

Nine Months ended
30th September 2025

2,282

Nine Months ended
30th September 2024

Key Financial Positions : Consistent Performance

Revenue from Operations (MINR)

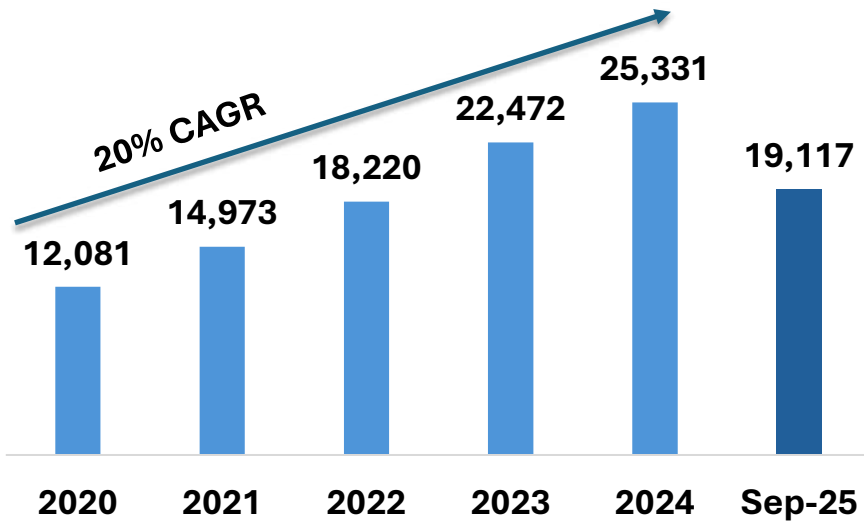

PAT (MINR)

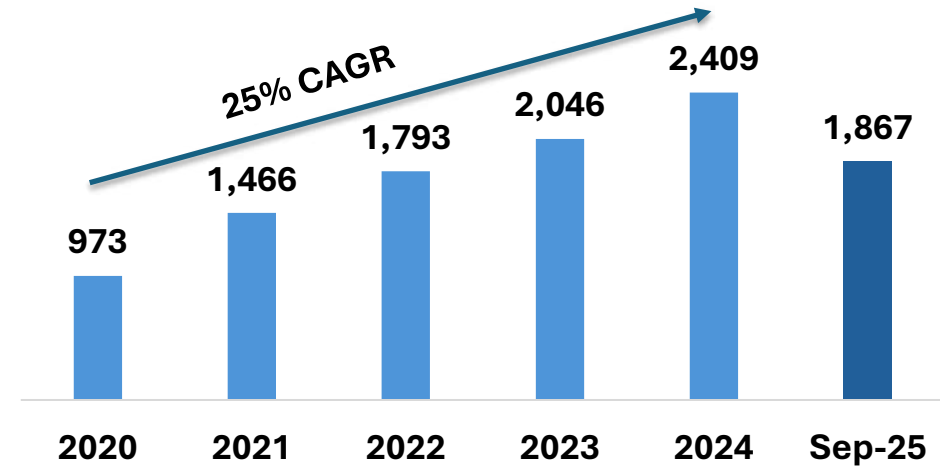

EBIDTA (MINR)

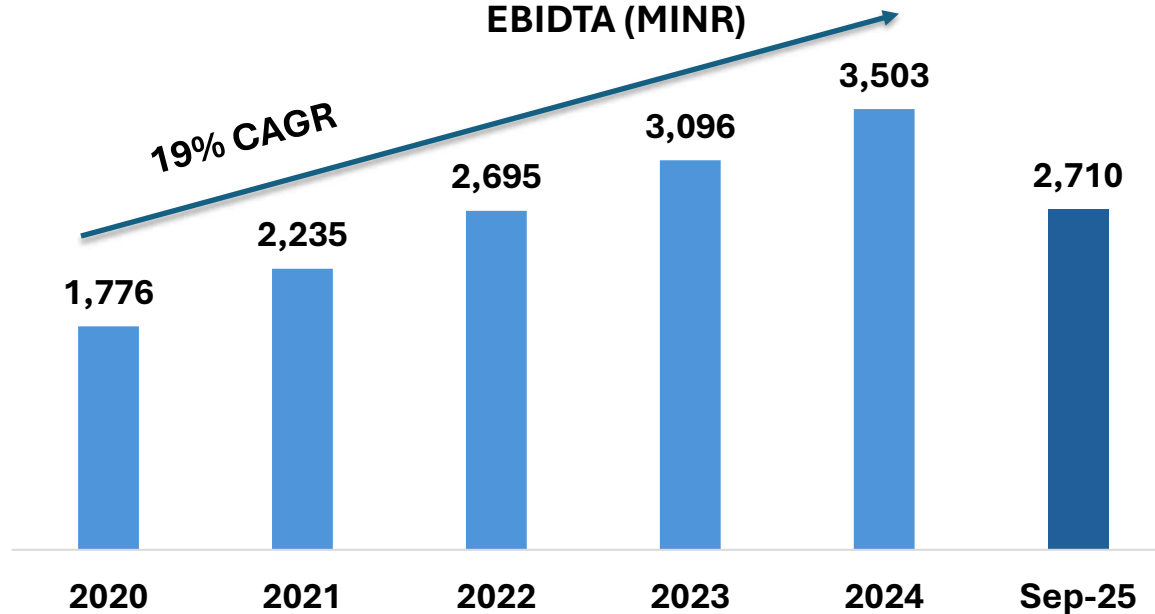

Consistent Value Creation for Investors

Net Worth (MINR)

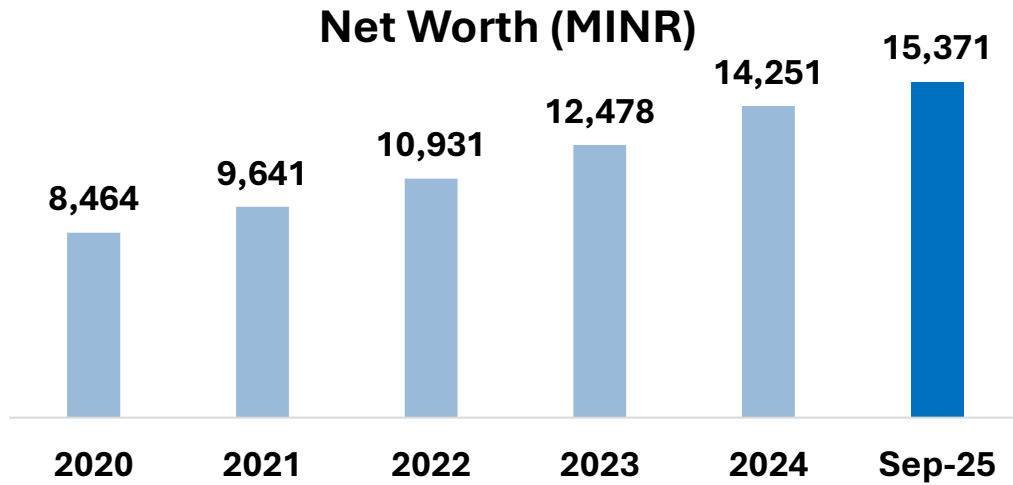

EPS (Adjusted Post Split)

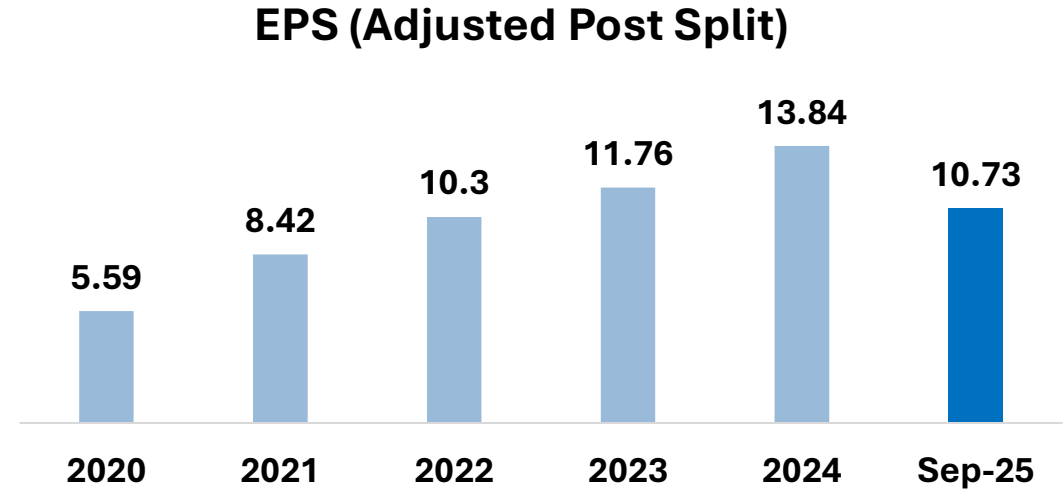

ROCE % (With Cash & Bank Deposits)

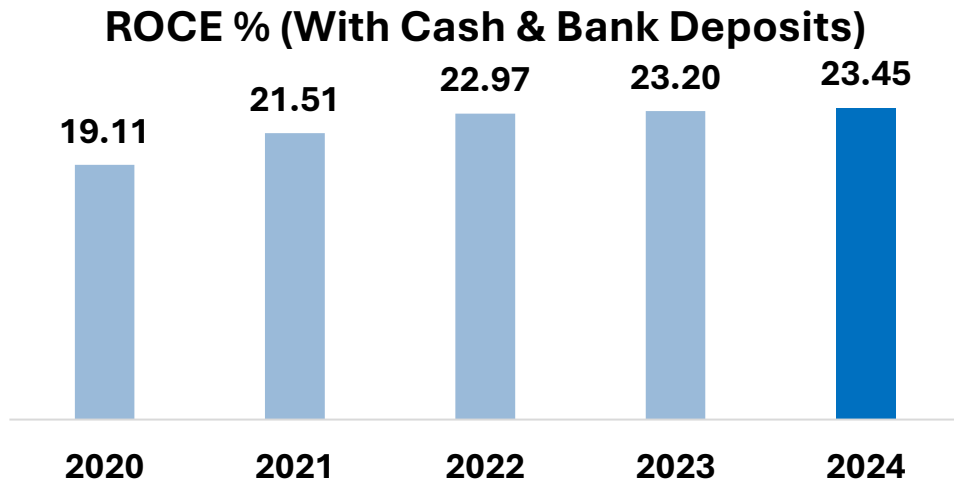

Dividend % for FY

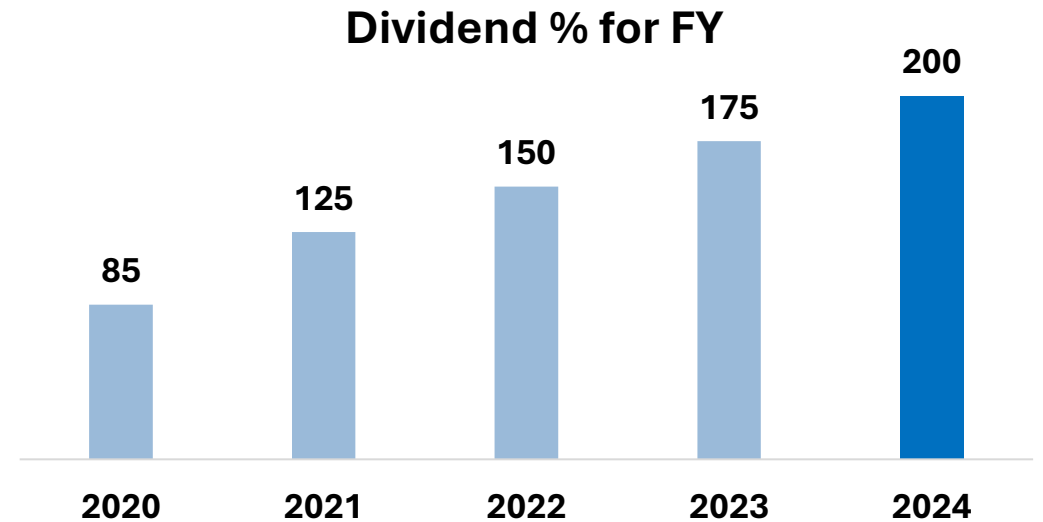

Net Financial Position

Net Finance Position	2023	2024	Sep-25
Without Nuclear	2,743	3,206	2,706
Nuclear	3	29	287
Total : with Nuclear	2,746	3,235	2,993

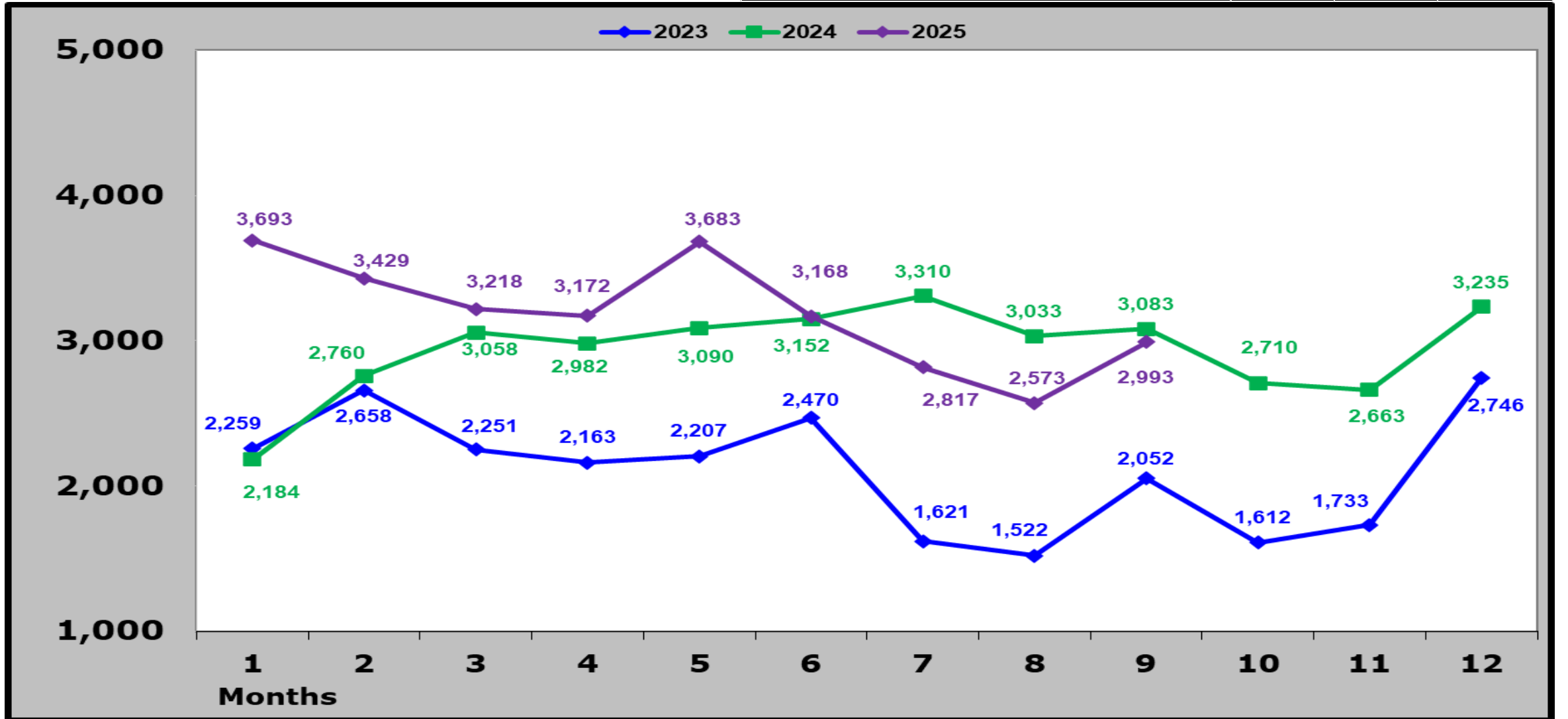

A photograph of a desk with a laptop, a blue sticky note, a small container of blue powder, and a printed business report. The report features several charts: a stacked bar chart at the top, a line chart on the left, and a bar chart at the bottom. A semi-transparent grey box with the text 'Business Highlights' is overlaid on the center of the report. The charts contain placeholder text like 'Lorem ipsum' and 'WED', 'THU', 'FRI', 'SAT'.

Business Highlights

Fields of applications for our products

Market Areas



ENERGY



BUILDING SERVICES



GENERAL INDUSTRY



**PETROCHEMICALS /
CHEMICALS**



MINING



WATER

6 market areas

21 submarkets

Order Intake On An Upward Trajectory

Order Intake (Domestic + Exports) w/o Nuclear Mio INR

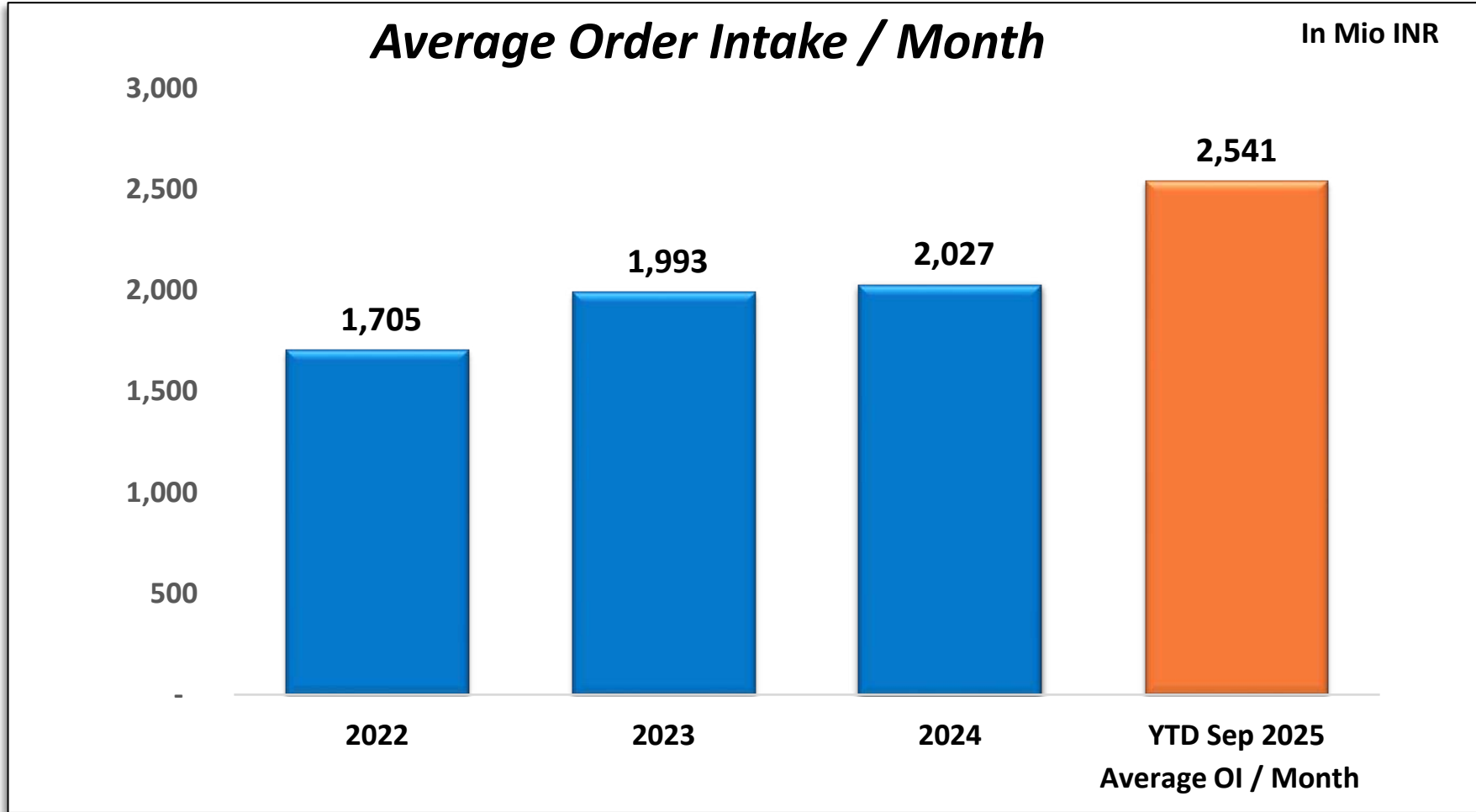

Remarks YTD Sep 2025 OI:

W/o Nuclear : **INR 22,869 Mio**

OI is steady and driven by below segments

- Supercritical
- Conventional Energy
- Exports – PCC and standard
- Water Waste water

Order On Hand

KSB Limited (Domestic + Exports)

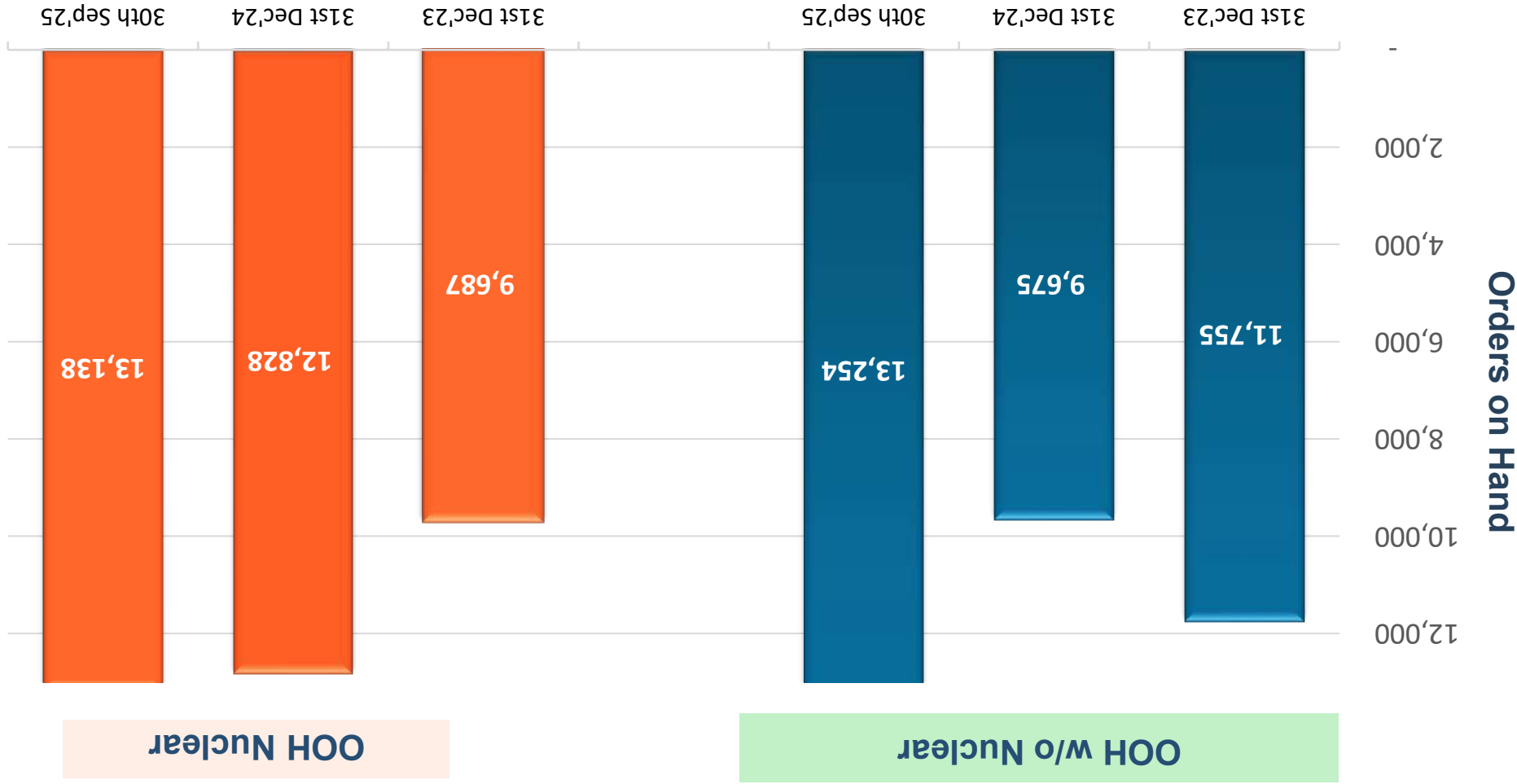

In Mio ₹

Top 10 customers (Domestic OI - w/o nuclear)

Total Year 2024

Customer	Segment
Thermax Group	Energy
Maharashtra State Electricity Ltd.	Solar
Maharashtra Energy	Solar
Rushabh Enterprises (Dealer)	General Industry
Dakshin Gujarat Vij Company	Solar
ISGEC Heavy Engineering	Energy
Patil Engineering (Dealer)	General Industry
Pooja Engineering Company (Dealer)	Chemical
Global Associates (Dealer)	General Industry
Deraz Engineers (Dealer)	General Industry

YTD Sep 2025

Customer	Segment
Larsen & Toubro	Energy
Thermax Group	Energy
Maharashtra State Electricity	Solar
ISGEC Heavy Engineering	Energy
Reliance Industries Limited	Petrochemicals
Megha Engineering	Petrochemicals
Swastik Trading Corp. (Dealer)	Valves
Pooja Engineering Company (Dealer)	General Industry
Haryana Renewable Energy	Solar
Rushabh Enterprises (Dealer)	General Industry

Highlights indicate different customers compared to previous list.

Export Performance

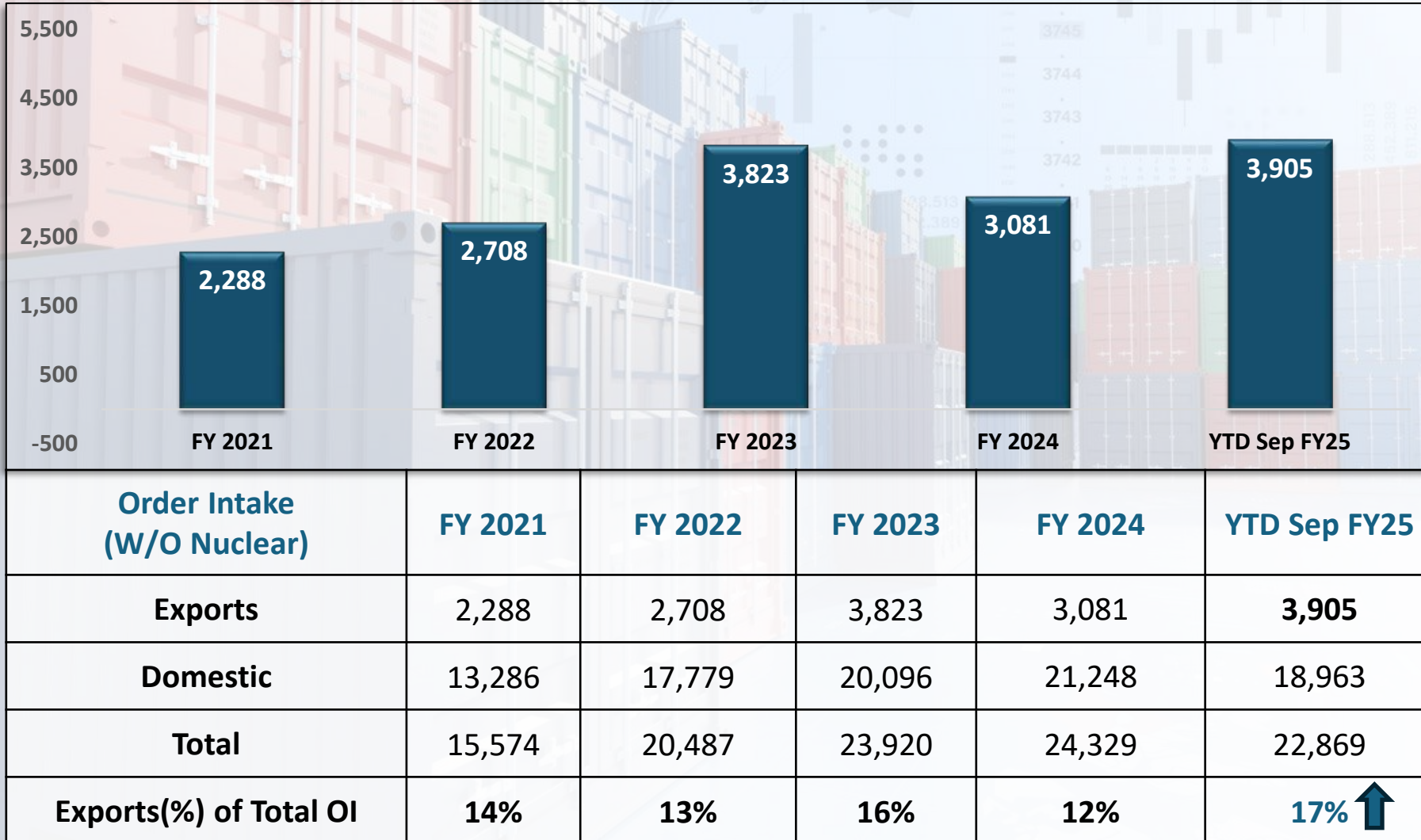



Energy Pumps Division, Shirwal

KSB India Growth Story – Sales and Marketing



📍 Energy Pumps Division, Shirwal

Our core segments

Fields of applications for our products



ENERGY



BUILDING SERVICES



GENERAL INDUSTRY



**PETROCHEMICALS /
CHEMICALS**



MINING



WATER

6 market areas → 21 submarkets

KSB India Order Intake continues to grow at a steady pace



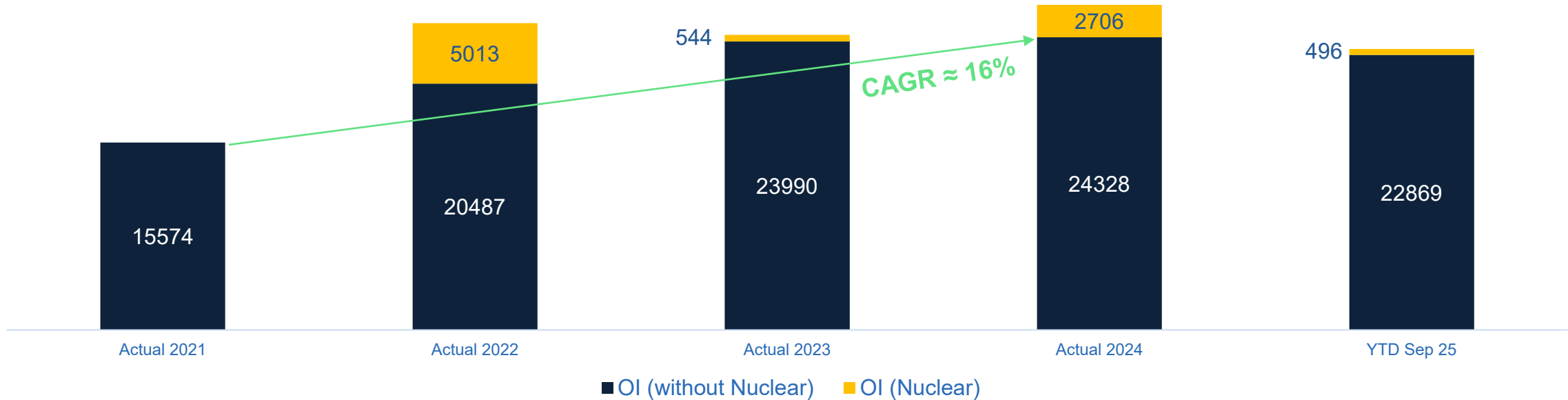





Order Intake Trend (in INR Mio)



- Non-nuclear business growing steadily with ~16% CAGR in order intake.
- Standard and Project segments form the core and largest share of our business and remain a key growth driver

Industry Segments Catered

Sales share, 3 Year Order Intake CAGR values for year - 2024

<p>Segment</p> <p>Sales share</p> <p>Our position</p> <p>Marquee customers</p>	<p>Water</p>  <p>29%</p> <p>Top 3</p> 	<p>General Industry</p>  <p>23%</p> <p>Top 2</p> 	<p>Energy</p>  <p>18%</p> <p>Market Leader</p> 
<p>Segment</p> <p>Sales share</p> <p>Our position</p> <p>Marquee customers</p>	<p>Building Services</p>  <p>8%</p> <p>Top 5</p> 	<p>Petrochemicals & Chemicals</p>  <p>21%</p> <p>Top 2</p> 	<p>Mining</p>  <p>1%</p> <p>New Entrant</p> 



Note:

1. Sales share represents sales revenue from segment as a % of total KSB Ltd revenue
2. Our Position represents competitive position amongst organised players in Indian market by revenue

Market Areas

Energy

Many people do not have access to electricity.





Booming Energy Sector In India To Meet The Rising Energy Demand

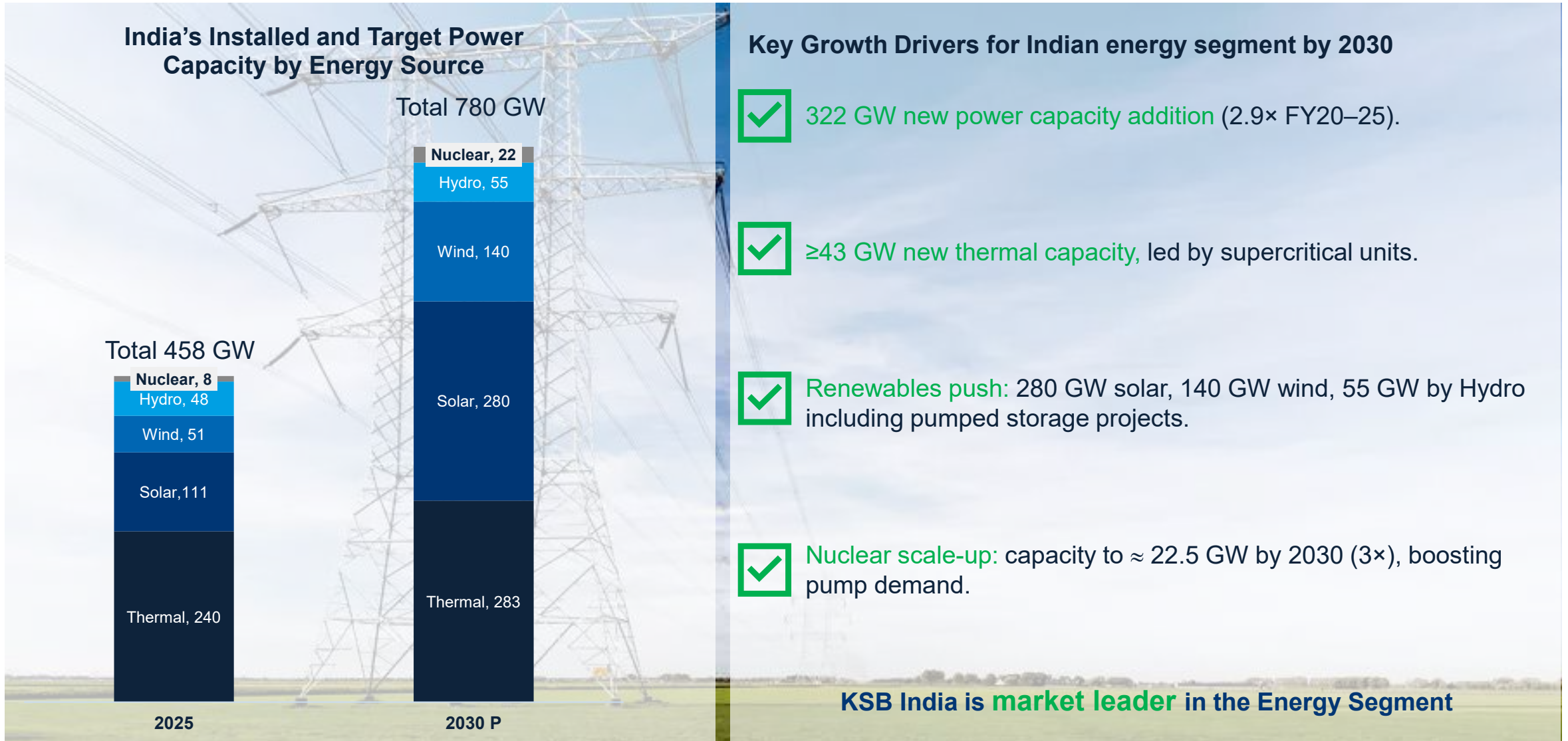

Order Intake Trend (Energy Segment)

Order Intake Trend

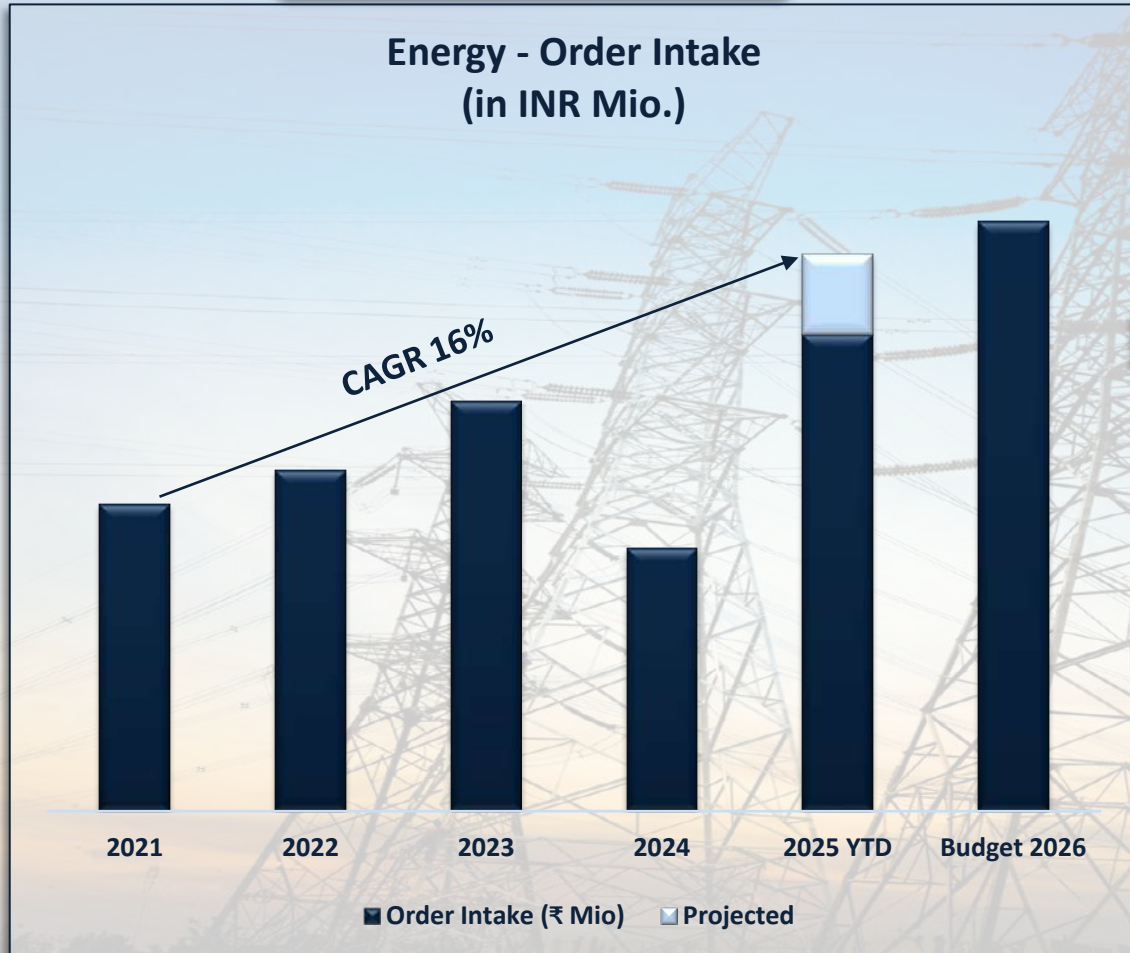

Major Order Wins in 2025

- Order received for 2 supercritical power plant projects
- Export order received from KSB Inc. USA for US based power project

Our Product Portfolio



HDA/ HGB/ HGC



CHTR



HG



CHTD



YNK



WKTA/WKTB

Water



The lack of water — particularly clean water — is one of the most critical issues of our time.



India's Water and Wastewater Infrastructure Surge

Water availability in India

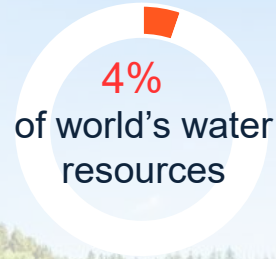

Indian water & waste water market

Indian Union Budget Allocation for Water Infrastructure (in Bn €)



Key Growth Drivers for Drinking Water & Sanitation

- ✓ **Jal Jeevan Mission:** Providing safe and adequate tap water supply to 19 crore households by 2028.
- ✓ **AMRUT (Atal Mission for Rejuvenation & Urban Transformation)** Improving urban infrastructure - Water supply & Sewage treatment.

Key Growth Drivers for Water resources

- ✓ **Mega River Linking Projects** Large inter-basin transfers in Uttar Pradesh, Madhya Pradesh, Tamil Nadu, Gujarat, and Maharashtra,
- ✓ **Rising coastal desalination investments** - Chennai (100–400 MLD) and Mumbai (2×200 MLD SWRO).
- ✓ **Wastewater treatment coverage set to rise** from ≈ 30% today to ≈ 80% by 2050.

KSB India ranks among top three pump manufacturers serving the water infrastructure segment in India

India's Water and Wastewater Infrastructure Surge

Order Intake Trend

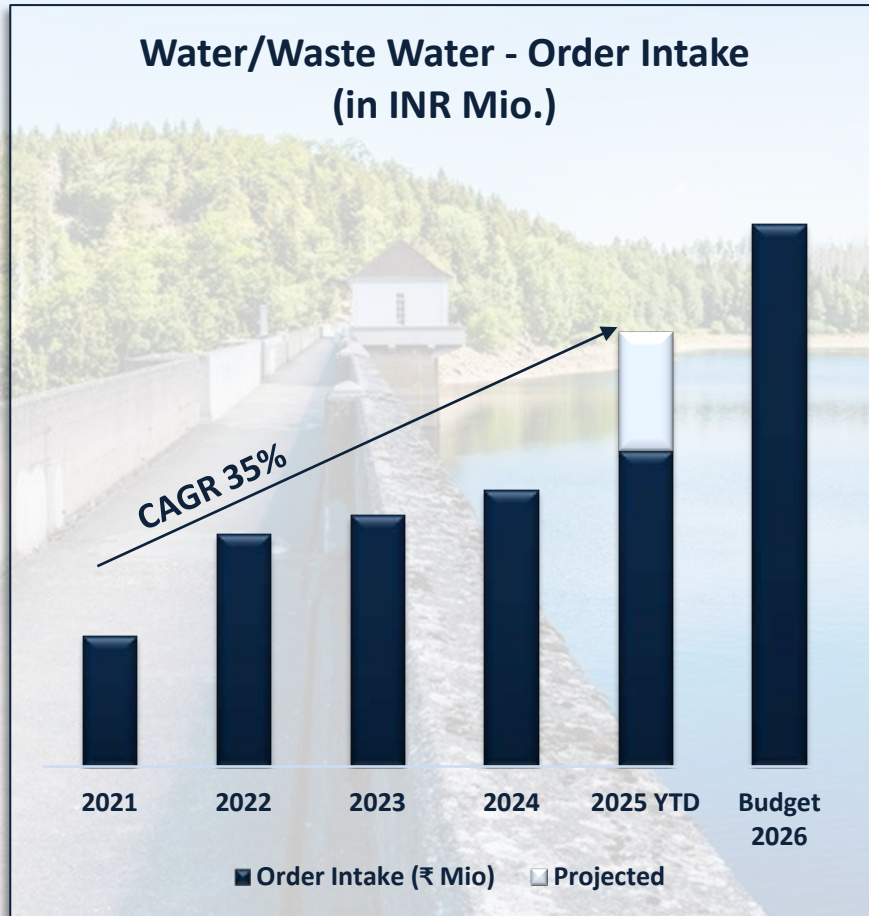

Major Order Wins in 2025

- 250+ mio INR order received for major municipal corporations like Kolkata, Bangalore, Greater Mumbai & Amritsar
- Orders received for Reliance Vinyls program, Nagothane
- First orders received for 3 Newly launched products - Sewatec , Vertical turbine pumps and K35

Our Product Portfolio



Amarex



Amaporter



KRTU



Sewatec

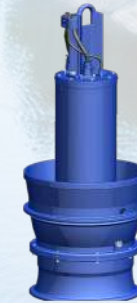

Amacan



VT Pump

Building Services

**Clean water,
hygienic conditions
and pleasant room
temperatures are
key to ensuring
our well-being.**



Infrastructure Boom Spurs Adoption of Global-Standard Fire Pumps

Firefighting pumps (by value)

Market size = INR 625 Cr

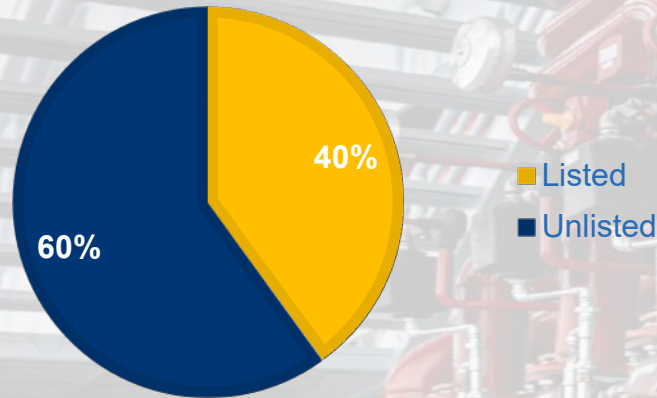

Firefighting pumps (by Quantity)

Market size = 12,100 units

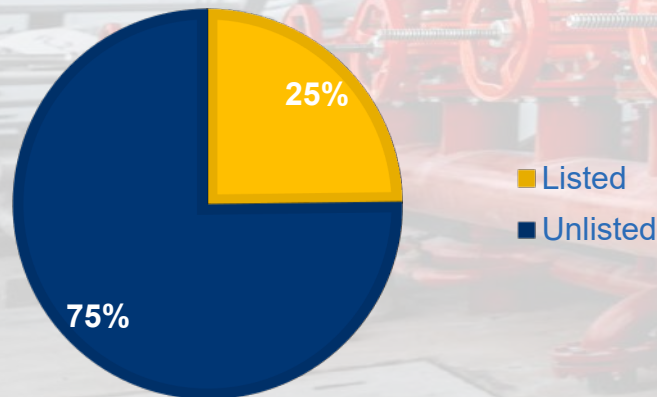

- India's firefighting pumps of INR 625 Cr in FY 22–23, with 12,100 units sold across applications.
- FM/UL listed pumps account for 40% by value, they are gaining traction in high-risk, safety-critical projects.
- Preferred by MNCs, metros, airports, tunnels, and high-rise buildings
- Rapid growth in infrastructure and safety awareness is driving increased adoption of listed pumps despite their higher cost.
- The shift toward certified, high-quality systems signals a positive trend in India's fire safety standards.

Firefighting Pump & Product Development- Update

Firefighting pump – Order Intake (In INR Mio.)

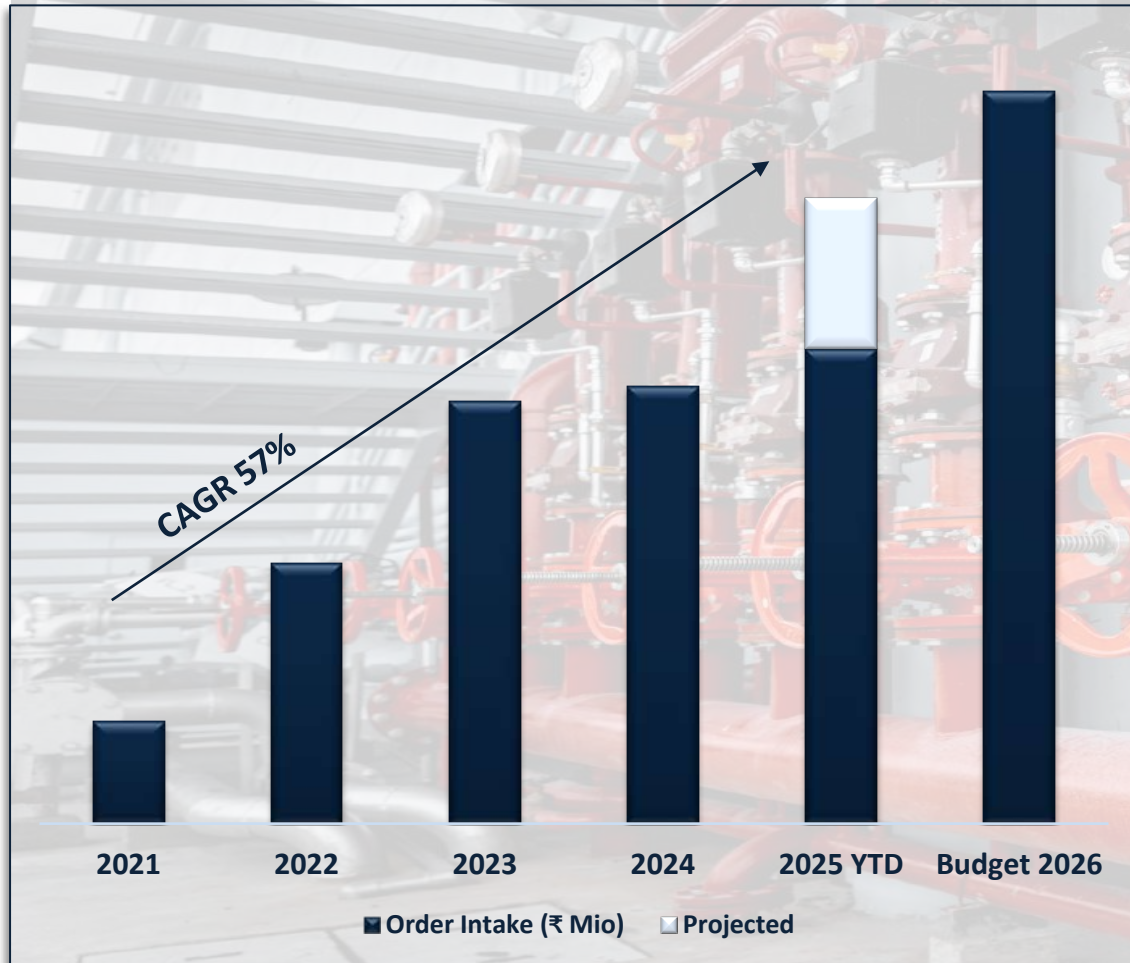

FM / UL Update

- ❖ ETN FXM: FM approved, UL certification by end of Nov- 25.

FM Approvals



Certificate of Compliance

This certificate is issued for the following:

Centrifugal Fire Pumps (Horizontal, End Suction Type)

<p>Design</p> <p>KSB SE & Co KGaA Johann-Klein-Straße 9 Dept CU-GP31 Frankenthal D-67227 Germany</p>	<p>Manufacturing and Packaging</p> <p>KSB Limited Irrigation & Process Division (IPD) Mumbai – Pune Road, Pimpri Pune, Maharashtra 411018 India</p>
---	--

Prepared for:

KSB Limited
Irrigation & Process Division (IPD)
Mumbai – Pune Road, Pimpri
Pune, Maharashtra 411018
India

Approval Standard: FM 1319 (August 2023)

Approval Identification: PR471804 Approval Granted: 15 October 2025

To verify the availability of the Approved product, please refer to www.approvalguide.com

Said Approval is subject to satisfactory field performance, continuing Surveillance Audits, and strict conformity to the constructions as shown in the Approval Guide, an online resource of FM Approvals.

David B. Fuller
David B. Fuller
VP, Manager – Fire Protection
FM Approvals
One Technology Way
Norwood, MA 02062



New Products introduced in 2025

Sl.	New Products	Details
1	FM approved - GAMMA FXF	Flow 3000 USGPM - Head \leq 16 bar
2	UL/FM approved - ETN FXM	Flow 1500 USGPM - Head \leq 16 bar
3	MFMO V - Vertical	Duty flow \leq 273 m ³ /h - Duty head \leq 40 bar
4	Helio X Controller	Controller for moviBOOST & HVAC System
5	Remote Monitoring System (RMS)	For moviBOOST system
6	Indigenous IE5 Motor with VFD mounting	Up to 45 KW - 2 Pole / 4 Pole



Gamma FXF



Etanorm FXM



Vertical MFMO



Helio – X Controller

Market Areas

General Industry

Be it for trains, cars, cosmetics or food — the global demand for industrial products is on the rise.



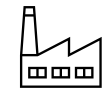

India's Manufacturing & Industry Boom

Manufacturing as a % of GDP

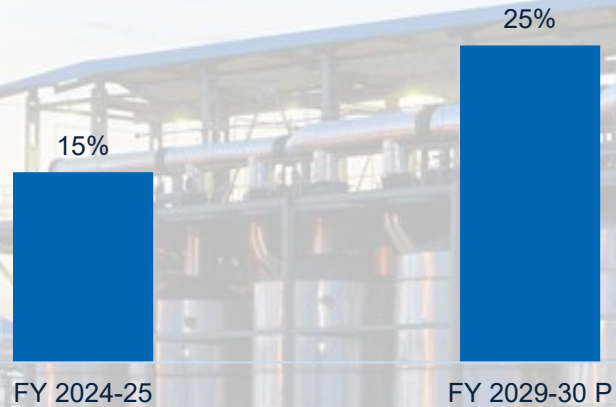

Index of Industrial Production (IIP, base 2011-12 = 100)

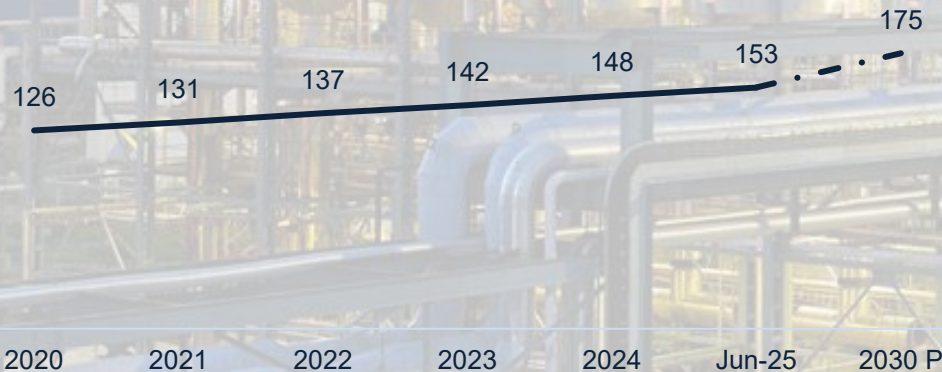

Key Growth Drivers

- ✓ **FDI & Global Shifts:** \$80+ Bn annual FDI in manufacturing; supply chain diversification (China+1 strategy).
- ✓ **Production Linked Incentive:** \$26+ Bn incentives for mfg. of Electronics, Semiconductors, Auto components, Pharma, etc
- ✓ **Expansion in food processing, sugar, distillery, & specialty chemicals,** growing at 8-10% CAGR over last 5 years
- ✓ **Rising infra spend on roads, metro & industrial corridors boosting steel & cement demand,** 8% CAGR over last 5 years
- ✓ **Rapidly growing emerging sectors like data center** with additional capacity of 7.1 GW announced (Current: 1.3 GW)

KSB India ranks among the top 2 pump manufacturers catering to the General Industry segment

Order Intake Trend – General Industry

Order Intake Trend

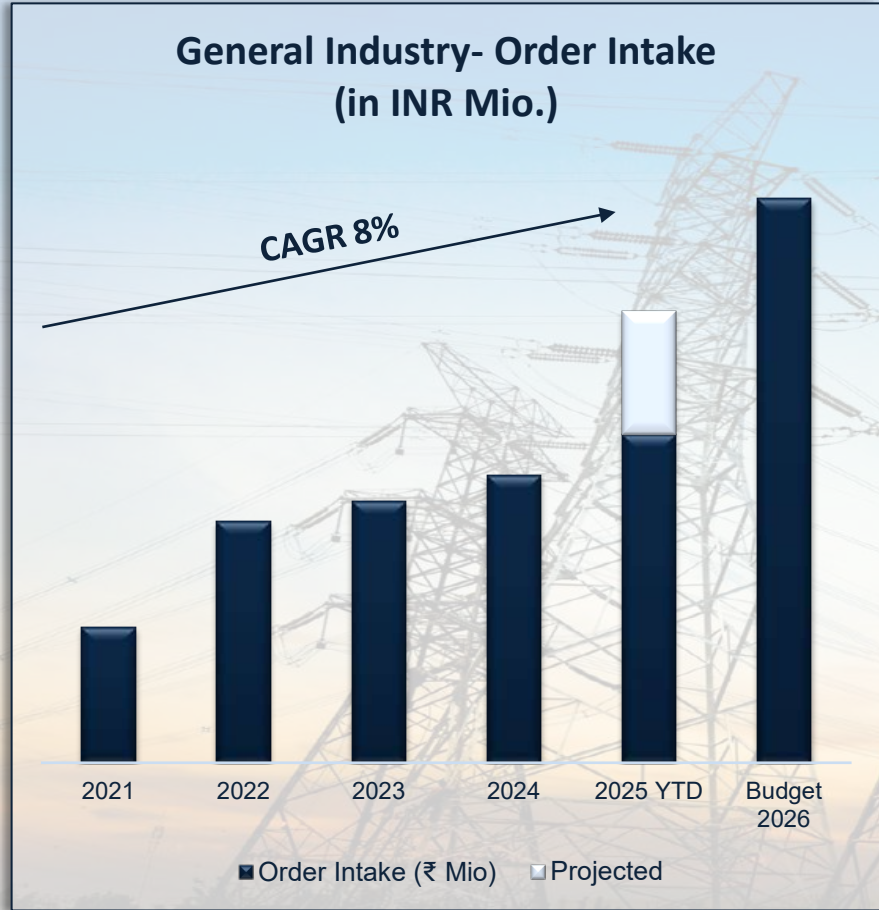

Major Order Wins in 2025

- 1200+ pumps supplied to 14 ethanol projects in line with 30% ethanol blending target for automobiles
- 100+ pumps supplied to major paper Industry customers – Satia paper, Kaantum paper, JK paper, Banwari paper etc.
- Received 8 big orders from Rungta, Tata Steel, JSPL, SAIL, Gajanan Ferro, PIML group

Our Product Portfolio



Etanorm



Etabloc



Etaline



Gamma / Omega

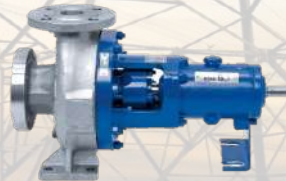

CPK SO



HPKL



KWP



KNCPP

Our Standard Business strategy

Key Growth Drivers for our Standard Business

Scale business from core products

For Ex: KRTs & B-pump in Water/WasteWater, Gamma & Movitec in General Industry

Strengthen our Agriculture & Domestic pumps business by strengthening distributors and dealer network

Scale new product lines & expand presence in sun-rise segments

Drive Digitization initiatives to support business development (Dealer Management Portal , Pricing tools, Dealer Digitization Schemes)

Sunrise Segments



Green Hydrogen
(Magnochem D)



Chemical Application
(Non-metallic pumps)



Railways
(Etaseco)



Fire-Fighting pumps



Life Science Application
(LSA)



Marine

Pump Requirements Being Catered

Indian Navy & Indian Coast Guard



Non-nuclear Submarines

- Biggest market in India till now
- Custom made pumps suiting to specification are being supplied –
- Stringer quality checks by Defence agencies successfully fulfilled by pumps of KSB
- Applications related functioning of ship – Bilge, Ballast, Fire-fighting, Fresh Water, Salvage, Refrigeration & AC



Warships & Coast Guard Ships

Maritime Segment / Commercial Ships



Commercial Ships /
Passenger Boats

- Upcoming market in India
- Spares, retro-fitment opportunities being fulfilled by standard marine products being localized
- Applications related functioning of ship – General Service, Bilge, Ballast, Fire-fighting, Fresh Water,

Marine Business India

Marine Products

Products Being Localized for Commercial Ships



ILN/ILNC/ILNR
10 sizes localization nearing completion



AU/AU-Monobloc
*2 size localized,
3 sizes at advanced stage*

Products for Naval Ships



Pumps as per Indian Navy Specifications
*3 Pumps type tested by Navy.
Further 6 Pumps type testing scheduled till Q1 26*

Marine Business India

Key Initiatives

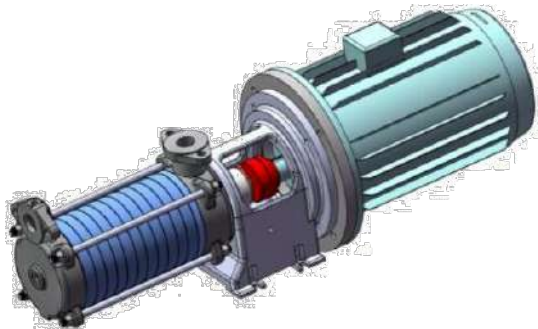

- **Approvals with Government Establishments**
 - Indian Cost Guard – Enlisted in approved **vendor list of shipbuilding 2 projects of 20 ships.**
 - Indian Navy – Enlisted in approved vendor list of upcoming shipbuilding project **of 8 ships**
 - Enlisted as approved vendor at all Government shipyards in India.
- **Increased visibility at Private Shipyards for tug boats, commercial ships.**
- **Localization of Marine products from KSB Spain**
- **Partnering with Marine OEMS of Refrigeration & AC Plants**

PRODUCT SERIES	PICTURE	PRODUCT DESIGN
Magnochem B (Block)		Single stage, ISO process pump with closed impeller magnetically coupled Application: Lye Circulation in Alkaline electrolysis
Mega CPK		Single stage, ISO process pump with closed impeller shaft seal Application: DM Water Transfer Application
Eta-Bloc (ETB)		Single stage, ISO process pump with semi-open impeller shaft seal Application: cooling water circulation
Movitec / Movitec LHS		Vertical Multistage centrifugal pump for Low flow- High Head application DM Water transfer / Ethylene Glycol mix transfer for WIND Application in cooling system
Etaseco RVP (Canned Motor)		Close coupled Canned Motor pump for Heat Transfer solutions in RAILWAY Segment for Traction converter system
KLS CR / CI / CF / LB (Hygienic pump series)		Hygienic Pumps specifically designed for applications that require high levels of cleanliness and sanitation , Applications: Commonly used in food, beverage, pharmaceutical, and biotechnology industries

New Technology

PRODUCT PORTFOLIO

Green Hydrogen / Ammonia

Train

Wind Power

Life Science Applications

Market Areas

Petrochemicals / Chemicals



**Synthetic
materials and
lubricants ensure
progress in day-
to-day life.**

Pumps for the Petrochemical market

Table 1—Pump Classification Type Identification

Pump Type ^a		Description		Type Code	
Centrifugal pumps	Overhung	Flexibly coupled	Horizontal	Foot-mounted	OH1
				Centerline-supported	OH2
			Vertical in-line with bearing bracket	—	OH3
		Rigidly coupled	Vertical in-line	—	OH4
		Close-coupled	Vertical in-line	—	OH5
			High-speed integrally geared	—	OH6
	Between-bearings	1- and 2-stage	Axially split	Foot-mounted	BB1-A
			Axially split	Near-centerline mounted	BB1-B
			Radially split	Centerline supported	BB2
		Multistage	Axially split	Near-centerline supported	BB3
			Radially split	Single casing	BB4
				Double casing	BB5
	Vertically suspended	Single casing	Discharge through column	—	VS1
				—	VS2
				—	VS3
		Separate discharge pipe	Line shaft	VS4	
			Cantilever shaft	VS5	
Double casing		Radially split	—	VS6	
			—	VS7	

^a Illustrations of the various types of pump are provided in 4.2.2.

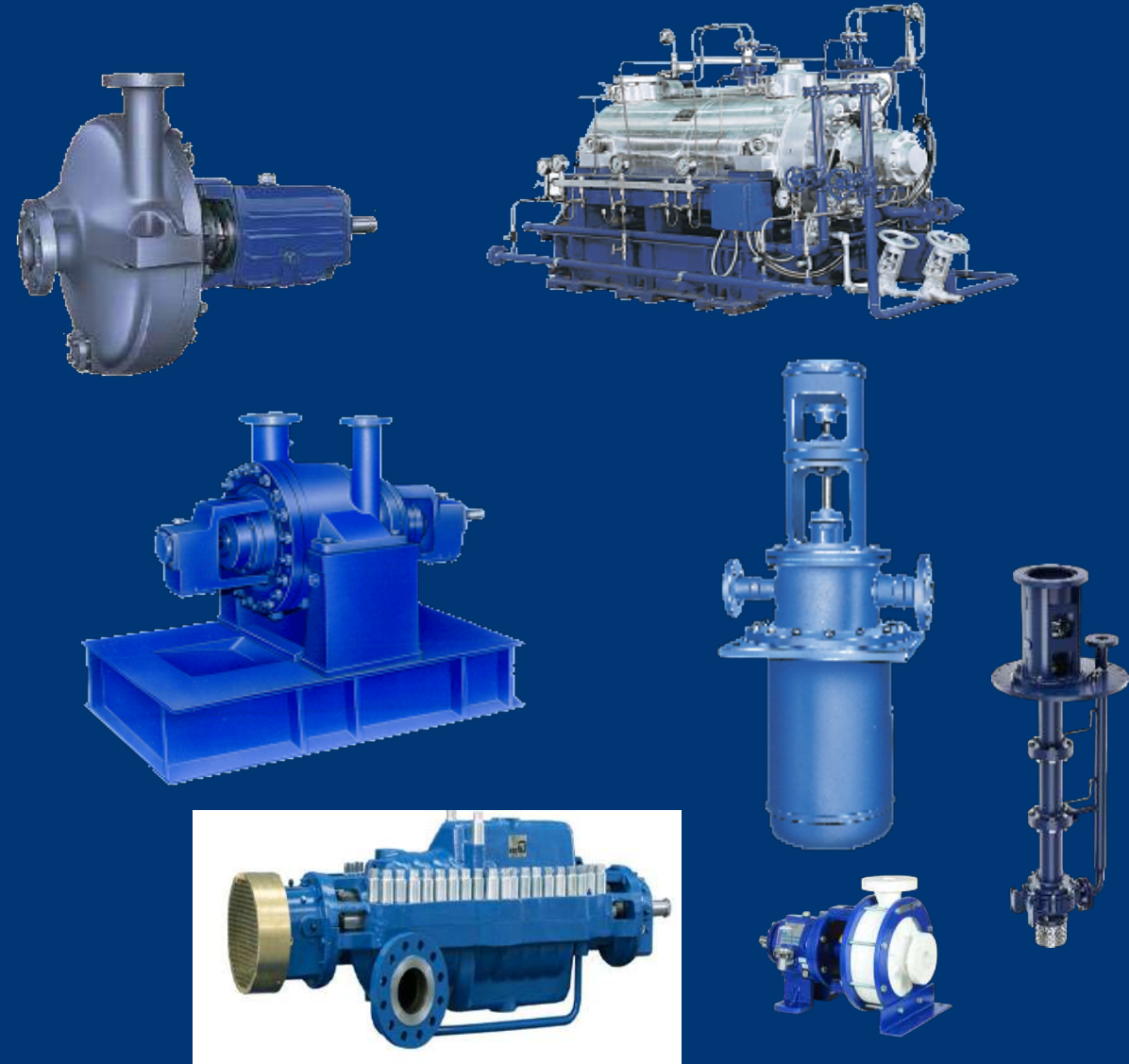

Mining



Electrification, urbanisation and wind power are increasing the need for raw materials such as copper and lithium.

Market Areas

Mining – New products introduced for Indian Market



VMD Pump



LCC Pump

Extensive Dealer Network Ensures We Are Accessible To Our Customers

Our sales network spread across India.



800+ Authorized dealers of Pumps and Valves



Our extensive channel partner network ensures we stay visible, accessible, and a trusted partner

KSB – A Trusted Brand, Made In India With German Precision

Cross Media Marketing



Hoardings



Street Umbrellas



Shop Branding

Mass-Media Presence



Television Ad



FM Radio Ad



TV Interviews

Digital & Social Media Presence



KSB India website



LinkedIn



KSB Intranet

Exhibitions & Fairs



Seminars



Trade-Fairs



Van campaigns

To Summarise!

- India's growth momentum is set to accelerate, driven by the Indian Govt's vision of a \$30 Trn economy by 2047
- Energy and Infrastructure will be key enablers—core to India's sustainable and inclusive development goals.
- KSB India is well-positioned to ride this wave with strong market presence and sectoral alignment.
- Presence in all sectors provides KSB an effective edge from any sectoral headwinds.
- Sunrise segments and SupremeServ will power our next phase of growth.
- Our Valves and Solar portfolio ensures a future-ready, diversified revenue base.

Well-Positioned to deliver **sustainable growth and long-term value creation**



SICCA Valves Division, Coimbatore, India



Contents



Valves Division- Coimbatore



Foundation

1987



Products

SICCA GGC
and ECOLINE-S



Employees

Approx. 325



Area

Total Area - 28,328 m²



SICCA - Wide range of Gate, Globe and Check Valves in Cast & Forged Construction
Ecoline – Ball, Butterfly, Dual Plate check Valves, Steam Trap

1 Plant, Product, and Sustainability Highlights

- *Plant Genesis*
- *Product Genesis*
- *Success Stories*

Plant Genesis

 1987

Construction of Factory at Coimbatore



 1997

Butterfly Valves, Advanced Welding, ISO 9001 Certification



 2010

HP Valves Range Enhancement: 18"-24" HP Valves



 2016

Range Enhancement: 3"-28" #3100/#3600 and 0.5"-2" #4500 Valves, Fugitive Emission Qualification



 2023

POV Execution, Motorized Gate Valves: 34" 900# PSV & 36" 150# LP



 1988

Commercial Production of Submersible Pumps and SICCA GGC Valves



 2005

Range Enhancement: 14"-24" LP & 14"-16" HP Valves, Dedicated GGC Valve Facility



 2013

Exclusive Shop for Big Diameter Valves and Capacity Enhancement



 2021

Expanded Range: 24"-32" #2500 Gate Valves, Pneumatic Actuator Integration, Digital Transformation



 2024

Order Based Developments, Execution of PK Orlen (Poland) Order.



Product Genesis

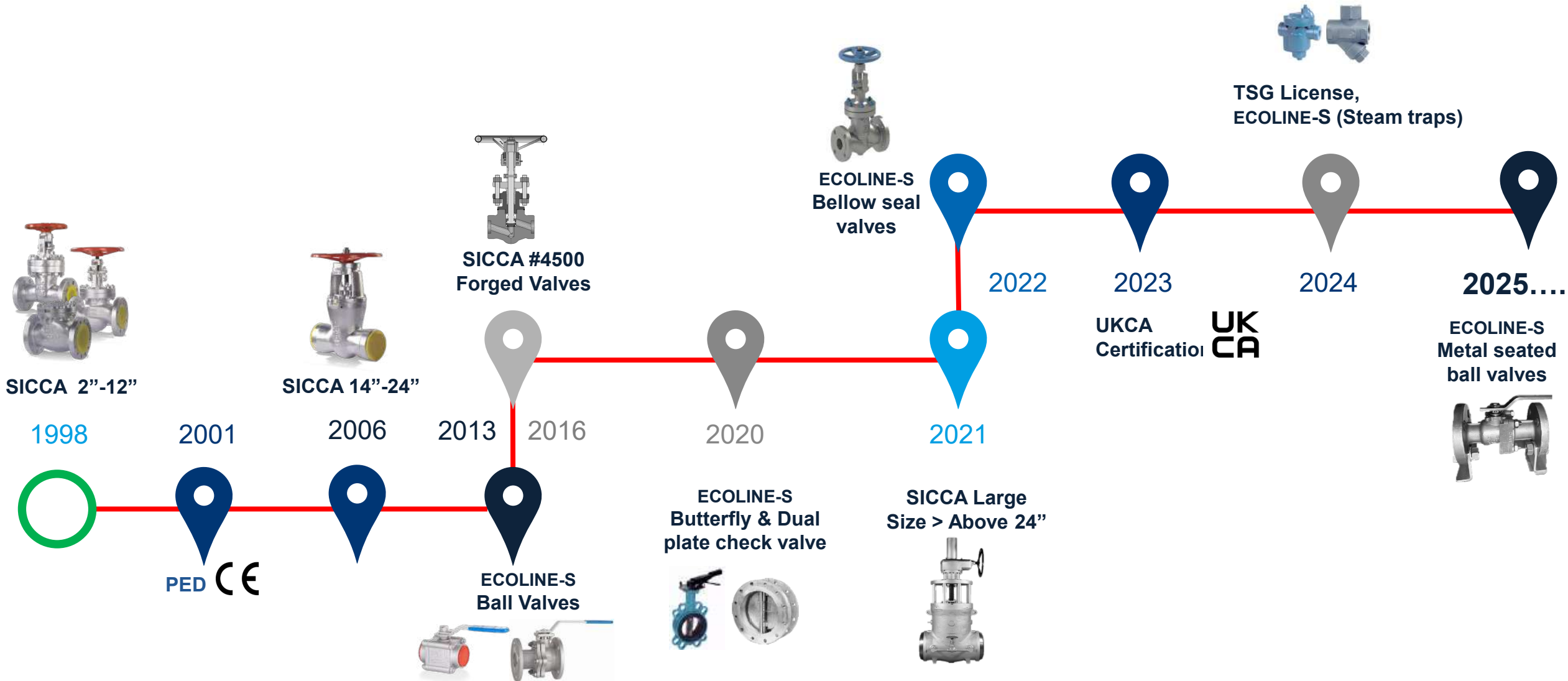

SICCA – Recent Developments



26" 150# SCC



28" 150# SCC



32" 600# GTC



34" 300# GTC



✓ Focus on Development of Bigger Size Valves

Manufacturing Range - SICCA

Valves are designed as per American standard

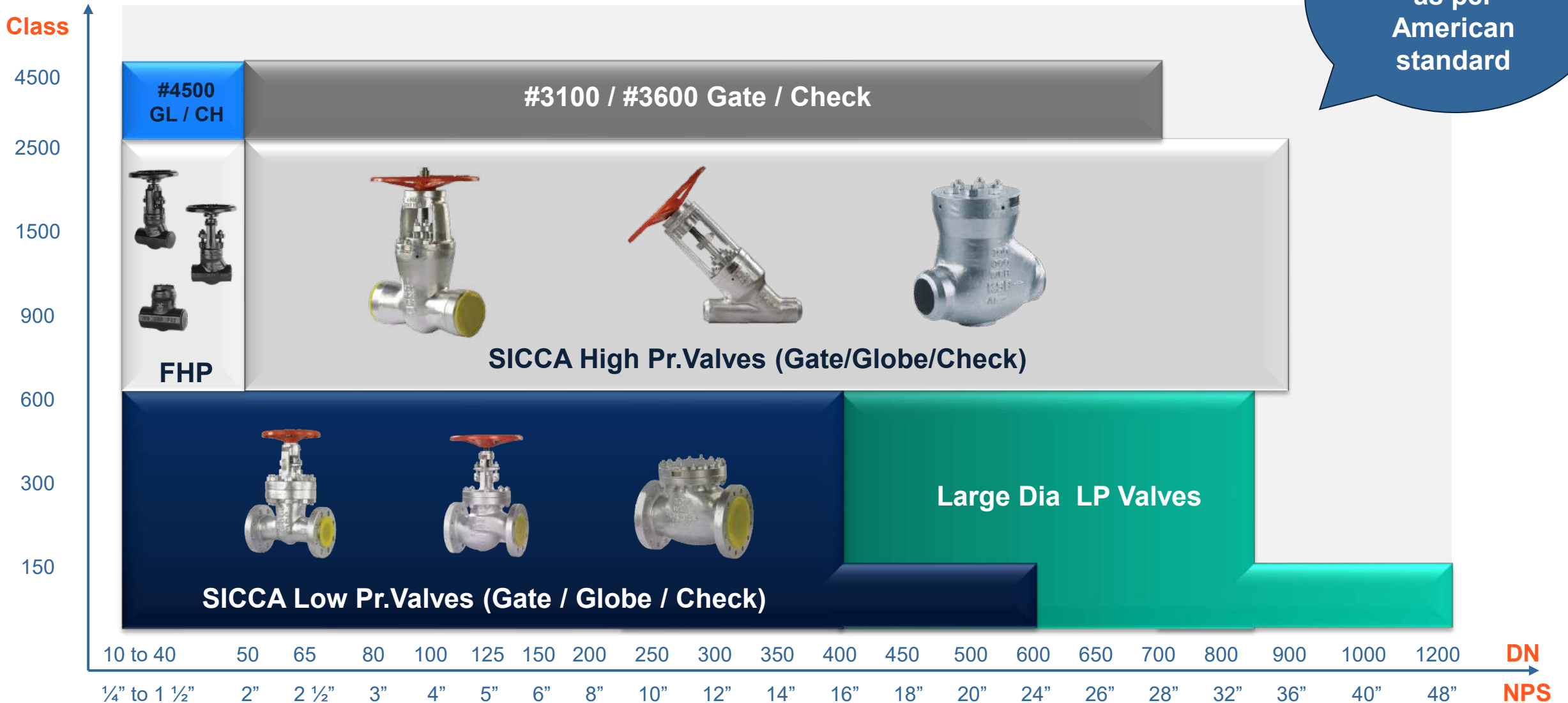

✓ Enhancing the Product Range in SICCA Range consistently

Success Story - TR PKN Orlen Order

Customer:



End Customer:



ORLEN

Record Order Value:

This is the largest Single Value order ever for KSB Coimbatore and a major reference for SICCA valves in the EU region.

New Valves Development:

Developed sizes from DN450 to DN850 with #150–#600 ratings, supplying a total of 63 valves for the project.

Material Compatibility:

To meet ASTM requirements at –29°C, we provided an equivalent DIN-grade material to satisfy the customer's needs.

✓ **Faster Development, New Metallurgy and On-Time Delivery**

Success Story – TSG China Accreditation

**中华人民共和国
特种设备生产许可证**
Production License of Special Equipment
People's Republic of China

编号/ No.: TS2700J10-2028

单位名称/Company: **KSB Limited**
住 所/Registered Address:
126, Maker Chambers-III, Nariman Point, Mumbai-400021, Maharashtra, India
制造地址/Manufacture Address:
151, Mettupalayam Road, NSN Palayam Post, Coimbatore-641031, Tamilnadu, India
经审查, 获准从事以下特种设备的生产活动:
Approved for the following production activities upon review and appraisal:

许可项目 Licensing Item	子项目 Sub-item	许可参数 Licensing Parameter	备注 Remark
压力管道元件制造 Pressure Piping Component Manufacture	压力管道阀门 (金属阀门) (A1、B) Valve on Pressure Piping (Metallic Valves) (A1、B)	—	具体产品范围见 型式试验证书 Refer to Type Test Certificate for Specific Limitation

发证机关: 国家市场监督管理总局
License Issue Authority:
State Administration for Market Regulation, P. R. China

有效期至: 2028年9月2日
Date of Expiration: September 2nd, 2028

发证日期: 2024年9月3日
Date of Issue: September 3rd, 2024



TSG/SELO license is essential for entering the Chinese pressure-equipment market.

KSB met stringent requirements and audits, overcoming timeline and compliance challenges.

CSEI's 3-day audit resulted in zero non-conformance, earning the CML on 2nd Sept 2024.

✓ **KSB is the first valve company in India to earn TSG certifications.**

Dealer Network

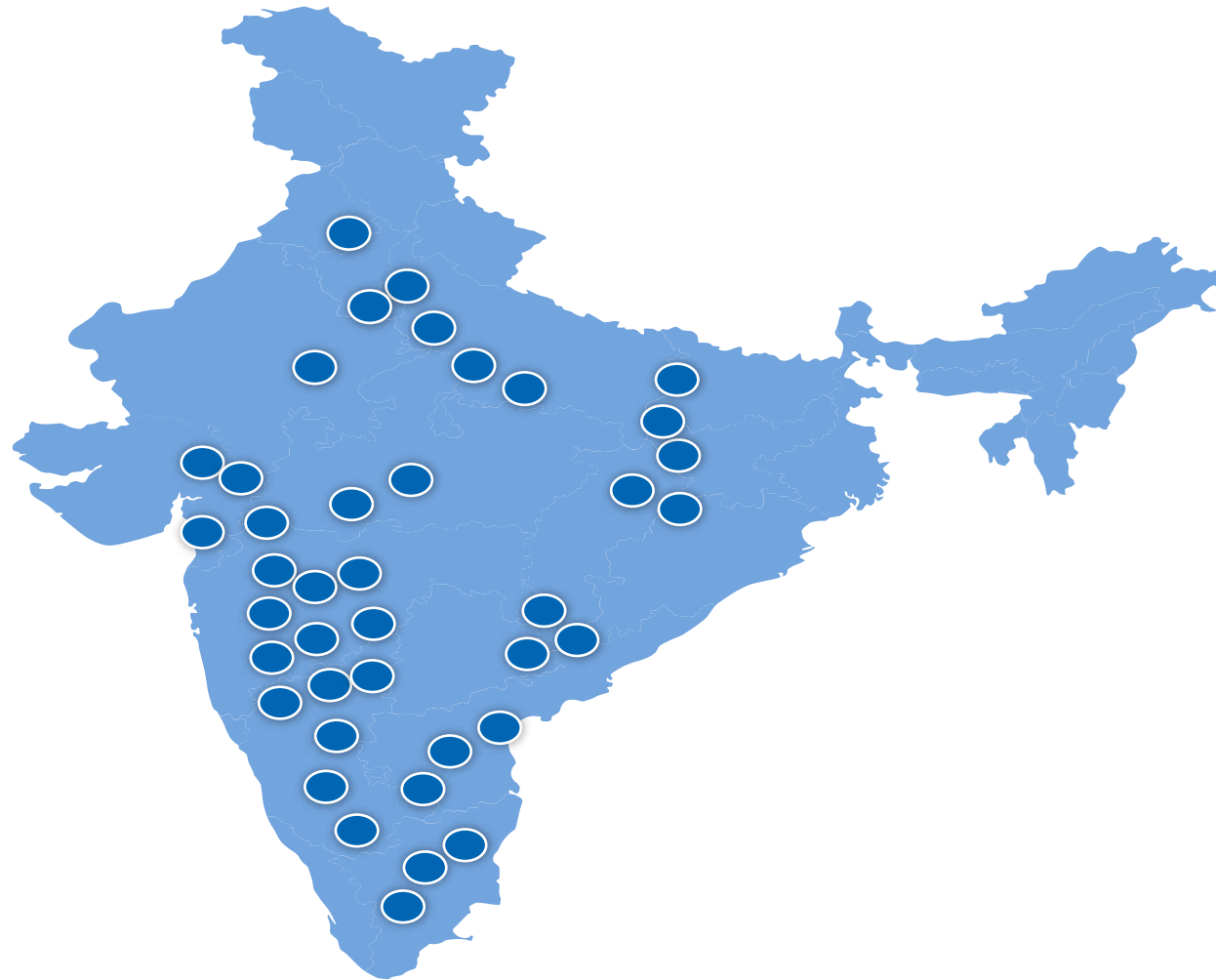

● Dealer Locations



✓ Exclusive Dealers for Valves

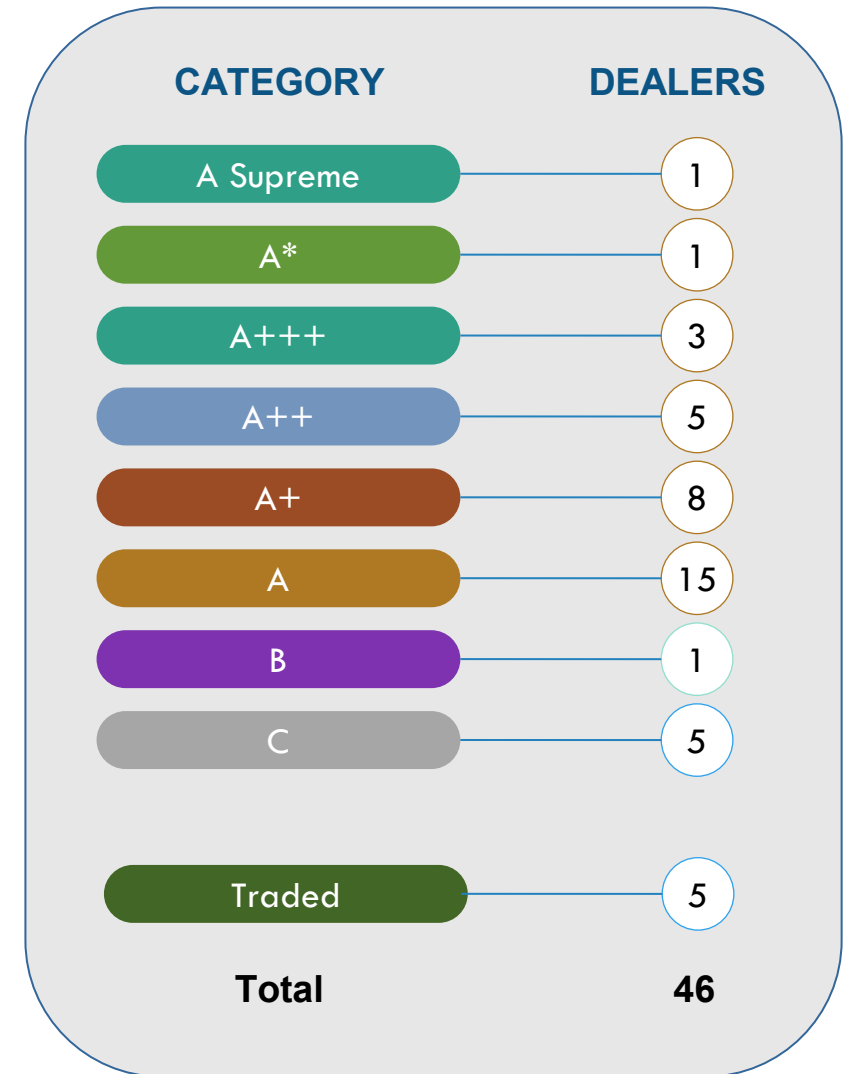

2 Business Overview and Outlook

- *Industries We Cater To*
- *Business Performance Highlights*

Industries We Cater To



ENERGY

Thermal Power Plants

Captive Power Plants

Waste to Energy

Green Energy



GENERAL INDUSTRY

Cement, Sugar

Steel, Pulp & Paper

Fertilizer, Chemical

Edible Oil



OIL & GAS

Refinery

Petrochemical

Natural Gas

LPG

✓ Strong Presence in Energy, General Industry and entry to Oil and Gas Market

Business Performance Highlights

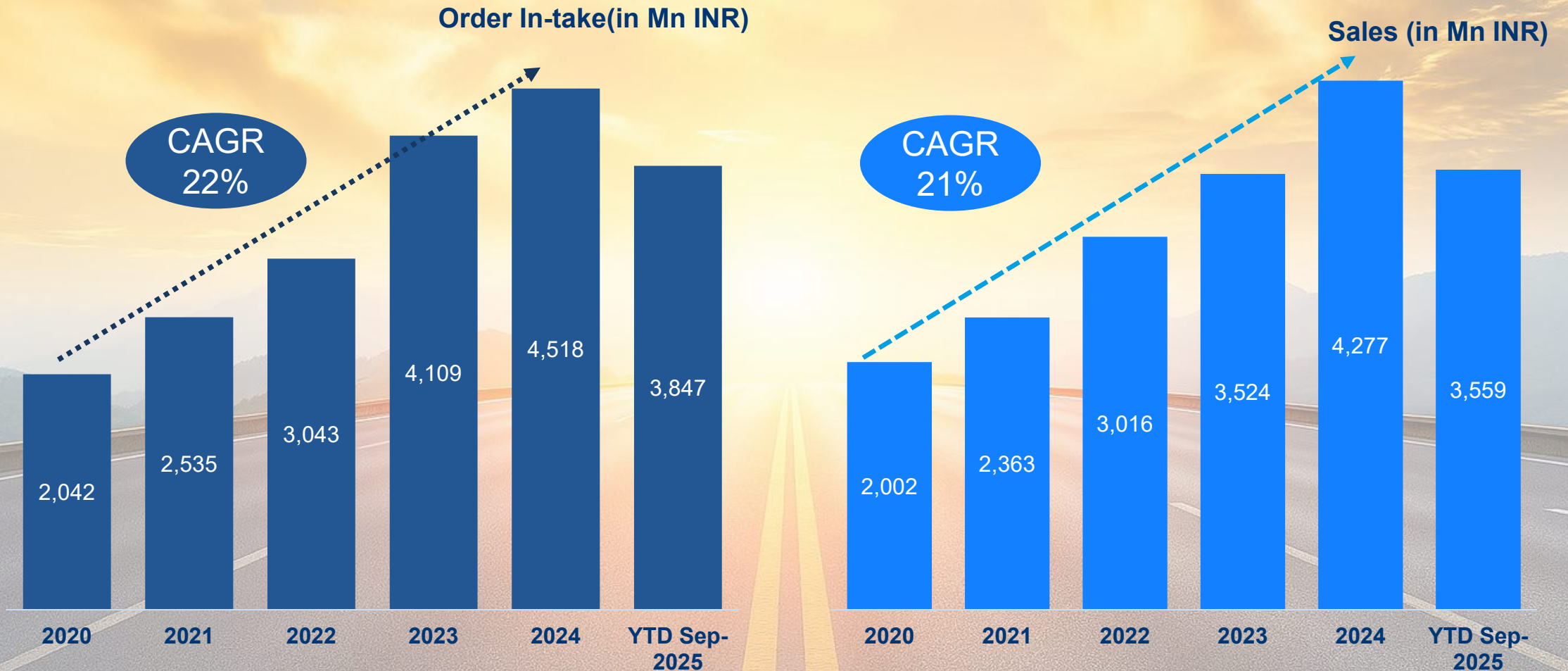

- ✓ Consistent YOY Growth in Order In-take and Sales
- ✓ Product Portfolio Enhancement
- ✓ Agile Supply Chain and Flexible Manufacturing

3

Technology and Process Transformation

- *Technology Adaptation*
- *Digitization Initiatives*
- *Supply Chain Strategy and Quality Strategies adopted*

Strategic Technology Adoption and Best Practice Integration



Hybrid Cell – Lean Concept



Precise 4Tonnage Wedge Grinding machine



Robotic Laser Cladding and Hardening System

Implementation of Latest Technology in Weld Overlay and Lean concepts, for Efficiency and Capacity Enhancement

Digitization Initiatives



Supply Chain Strategy

- ✓ Additional Pattern Development
- ✓ Single Source Mitigation

- ✓ API Foundries
- ✓ Pressure Seal 2”- 16”
(8 Foundries approved)

- ✓ Strategic alignment with critical Bought out like Actuators

- ✓ New Foundry for Bigger Size valves
- ✓ IBR Foundry Qualified and Approved

- ✓ Strategic sourcing for Order Based Development

Pro-active measures and Investment on Additional Patterns and New Vendor Development

Quality Strategies adopted

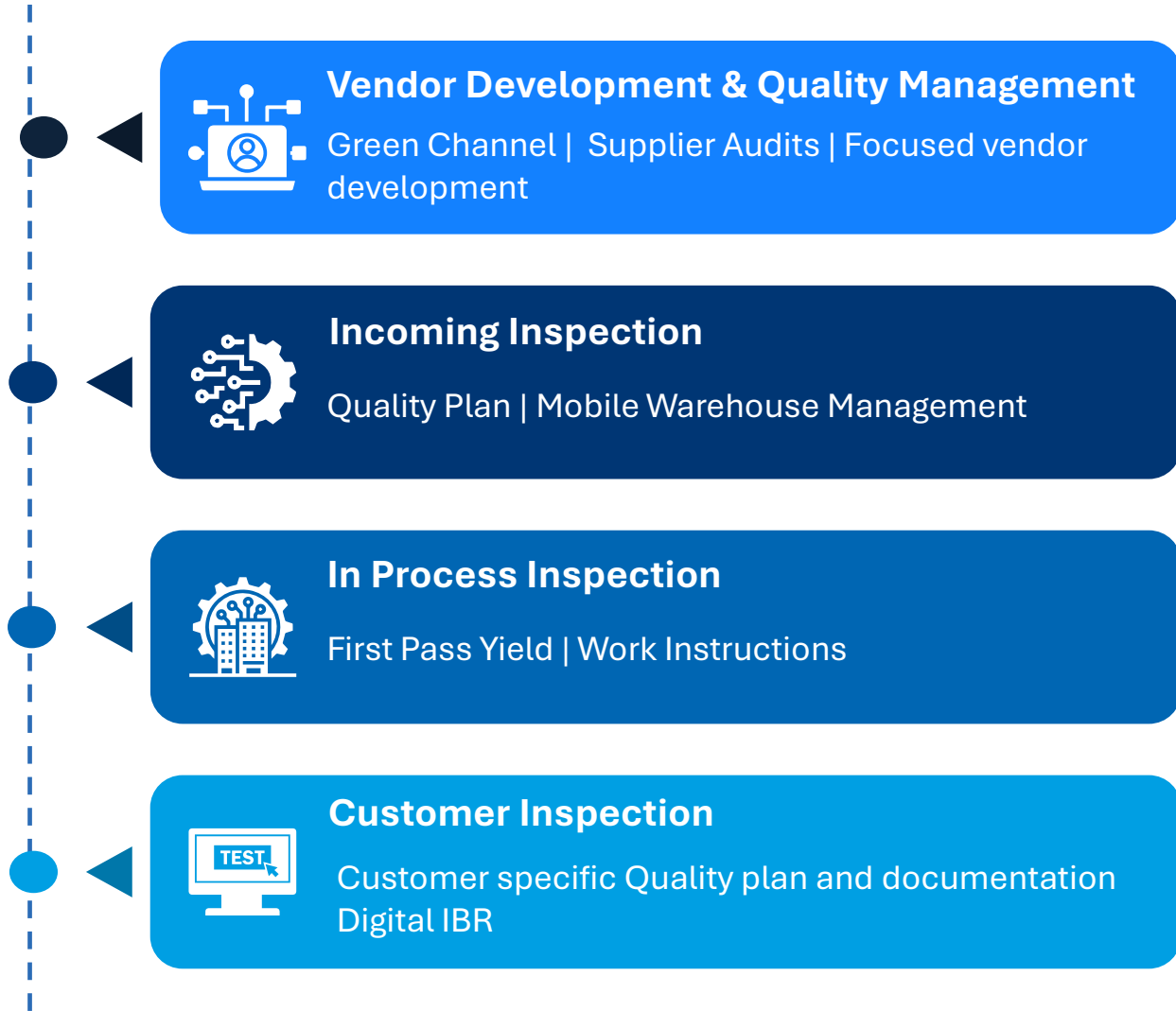

4

Safety, ESG Initiatives & Employee Engagement - Coimbatore

- *Safety Initiatives*
- *Environmental Social Governance*
- *Corporate Social Responsibility*
- *Employee Engagement*

Safety Highlights



Installation of Automatic Fire Sprinkler System at High-Risk Areas.



Total flooding system for server room.



Plant-wide Fire Suppression for Critical Electrical Panels

KSB Coimbatore Wins Prestigious Platinum Safety Excellence Award by the National HRD Network (NHRD), Coimbatore Chapter!



Environmental Social Governance



553 kW (AC) Roof top solar generation commenced in Jan 2025, with an estimated annual CO2 reduction of 660 MT



Carbon Footprint Reduction by **130 MT in 2024**

"TUV NORD appreciates KSB's energy conservation initiatives and upfront actions towards ESG"



Coimbatore Plant Bags the Sustainability Challenger Award - Twice Over!

Plant Amenities and Highlights



Corporate Social Responsibility Highlights



Skill Development – ITI Kavundampalayam

School Infrastructure Project

Employee Engagement Highlights



5

Next Steps

- *Way Forward*

Way Forward



New Market

- ✓ Oil and Gas
- ✓ General Industry Non-IBR



New Products

- ✓ SICCA - ASME & Bellow Seal Valves
- ✓ Ecoline-S Metal Seated Ball Valves
- ✓ Ecoline-S Knife Edge Gate Valves



New Qualification

- ✓ API Monogram
- ✓ SAMMS Specification



Manufacturing Strategy

- ✓ Efficiency Improvement
- ✓ Smart / Latest Technology Adaption
- ✓ Capacity Enhancement



KSB SupremeServ

Investors meet- SupremeServ overview





What is SupremeServ?

SupremeServ Location



- Power Projects Division established in 1978 at Chinchwad, Maharashtra.
- Now, this division is dedicated for SupremeServ activities.
- Total plant area is 15,000 Sq. meters.

SupremeServ facility



Central Warehouse



Seal manufacturing



Reverse Engineering



Seal Repair Centre



Machine Shop



Office Area



BCP Repair Lab



In-house Repairs

SupremeServ Tree

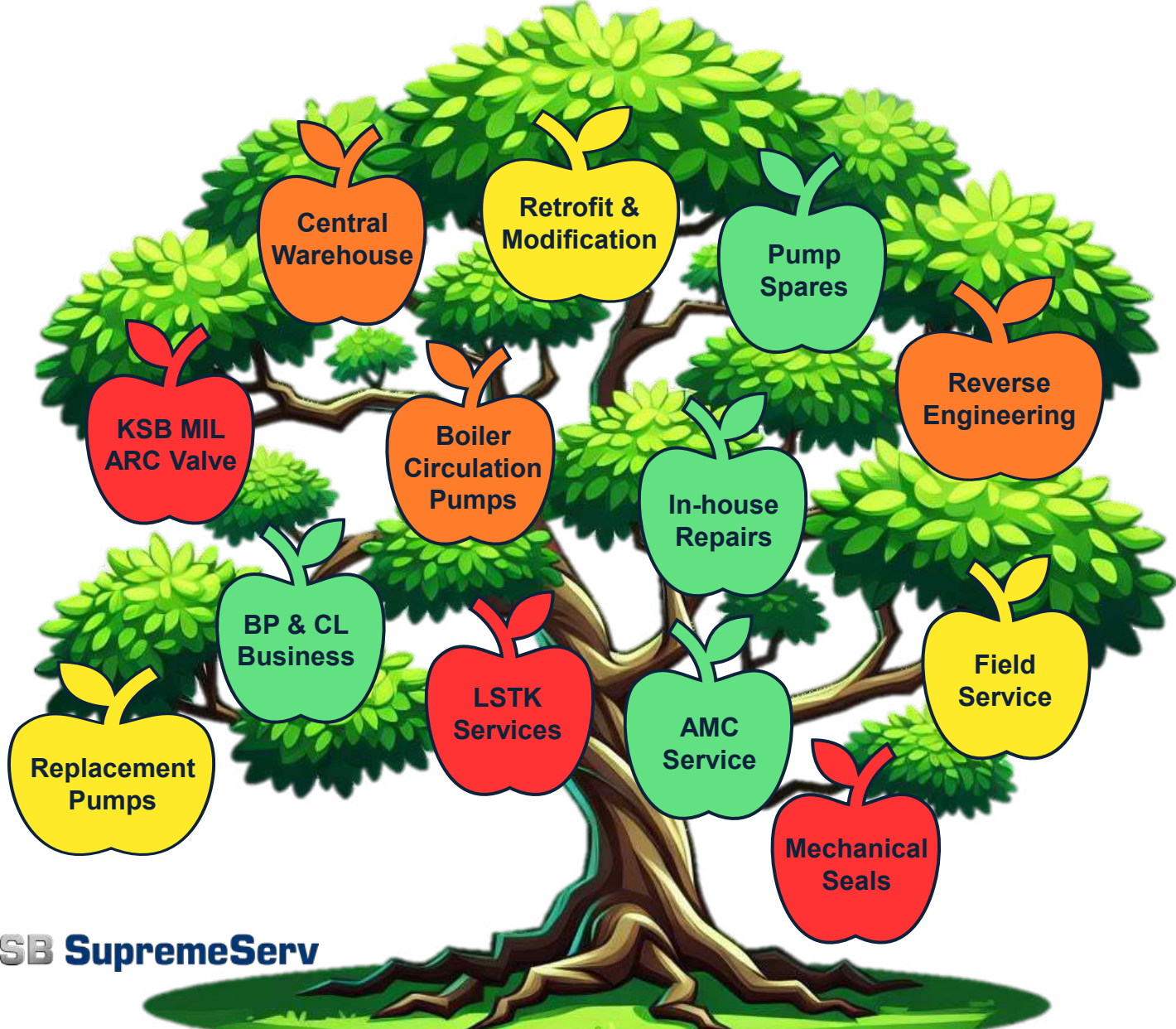

SupremeServ Tree

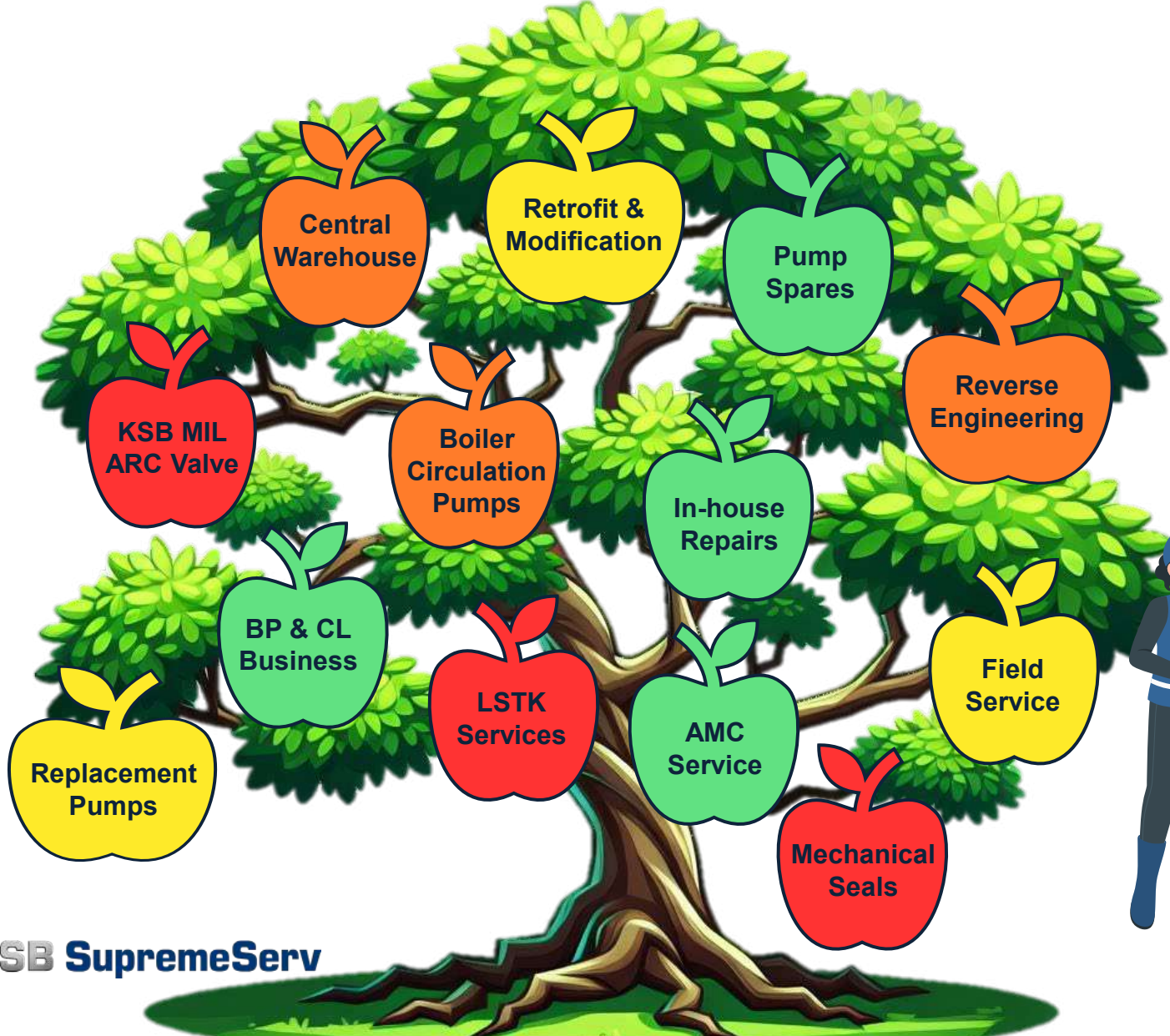

New Additions





SupremeServ Offerings

SupremeServ Offerings

Spares



1. Standard pump spares
2. Engineered pump spares

Service



1. Inhouse repairs
2. Retrofitment
3. Replacement
4. Other services

Digitization



1. KSB Guard
2. KSB Sonolyzer



SupremeServ Spares

Engineered pump spares



VTL (KBL Make)



BALANCING MACHINE



Radial Drilling Machine (RM63)



LATHE MACHINE NH26



After market support for engineered pump's spare parts.

Genuine spare parts manufactured under stringent design standards, guaranteeing consistent quality, durability, and performance.

Standard pump spares



North Zone

- Total No of ASC's: 25



East Zone

- Total No of ASC's: 13



West Zone

- Total No of ASC's: 21



South Zone

- Total No of ASC's: 17

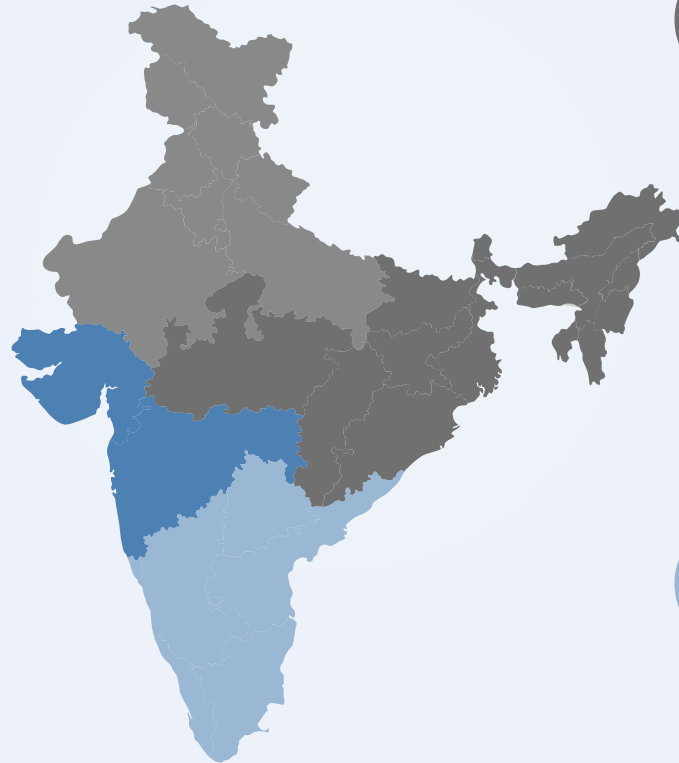

- **Total No of ASCs - pan India: 76**

Spares distribution through Central Warehouse



- Renovations



- Export Orders Packing Table



- Dedicated Packing Area



- Dedicated mechanical seal storage

Total Area

2,600 m²

Bin locations

14,000 Nos

Mechanical Seal facility



Seal Repair Centre

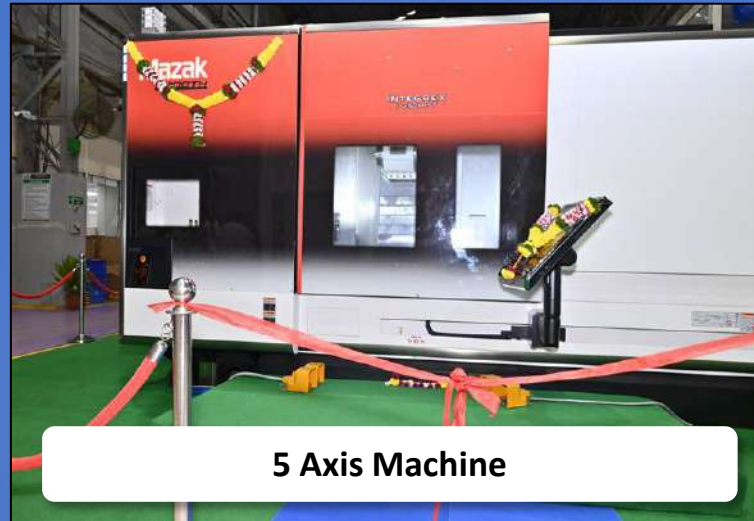

5 Axis Machine



Mechanical seal production

State-of-the-art
machinery

Dedicated dust free
facility

Well-trained
professionals

100% air leak testing



SupremeServ Services

SupremeServ Services



1. Inhouse repairs
2. Retrofit and Modification
3. Replacement
4. Field Services
5. Reverse Engineering
6. Boiler Circulation Pump
7. Optimisation Services
8. Automatic Recirculation Valve
9. BP&CL Business



In-house Repairs

A refurbishment facility equipped with state of the art equipment's for overhauling, repairing and re-conditioning Centrifugal pumps

KSB SupremeServ

In-house repair



Service Center in Baddi



Service Center in Odhav

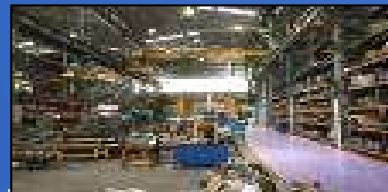

Service Center in Pune

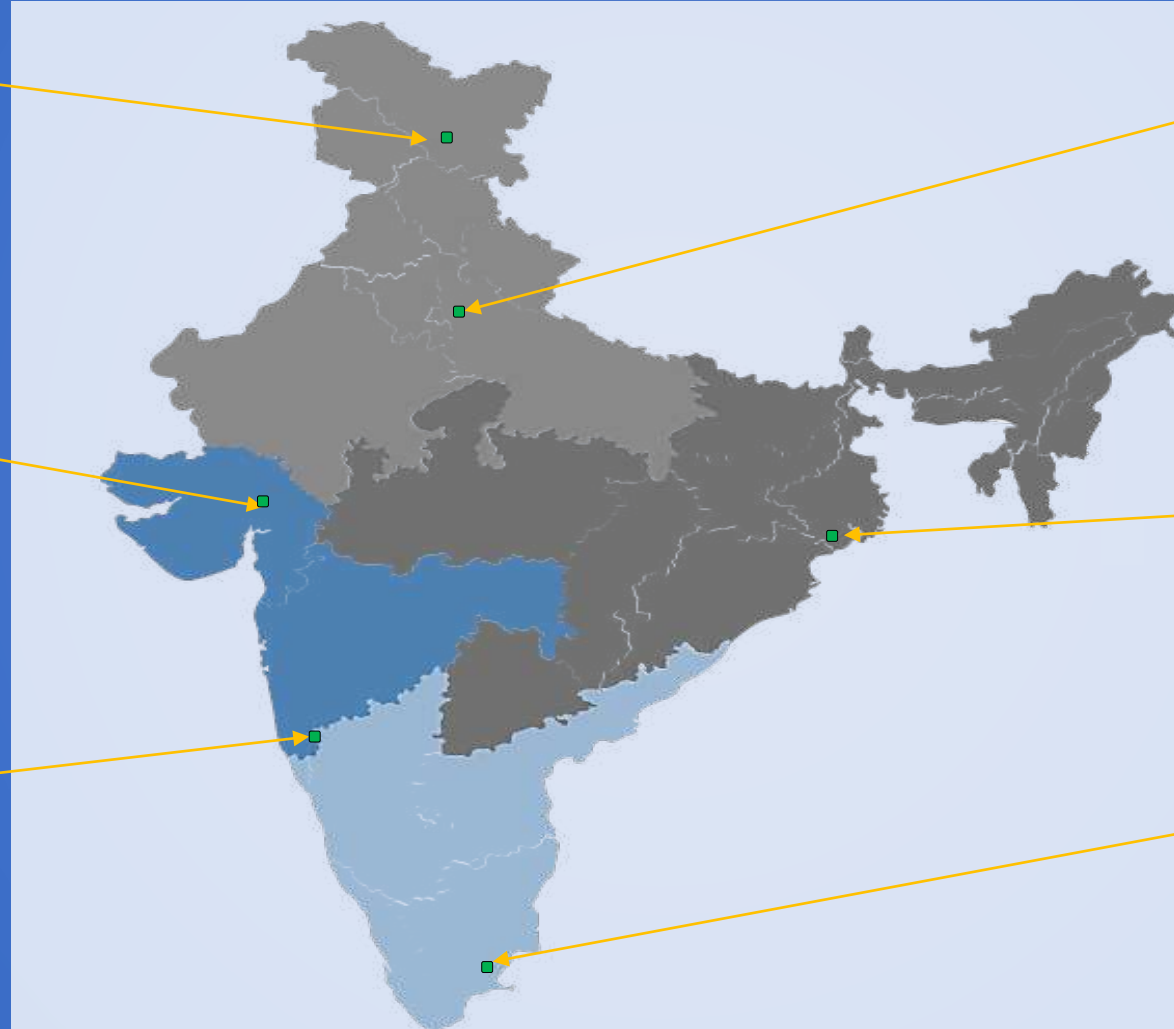

Service Center in Noida

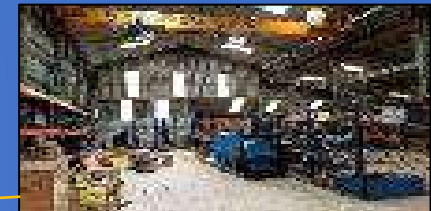

Service Center in Howrah



Service Center in Chennai

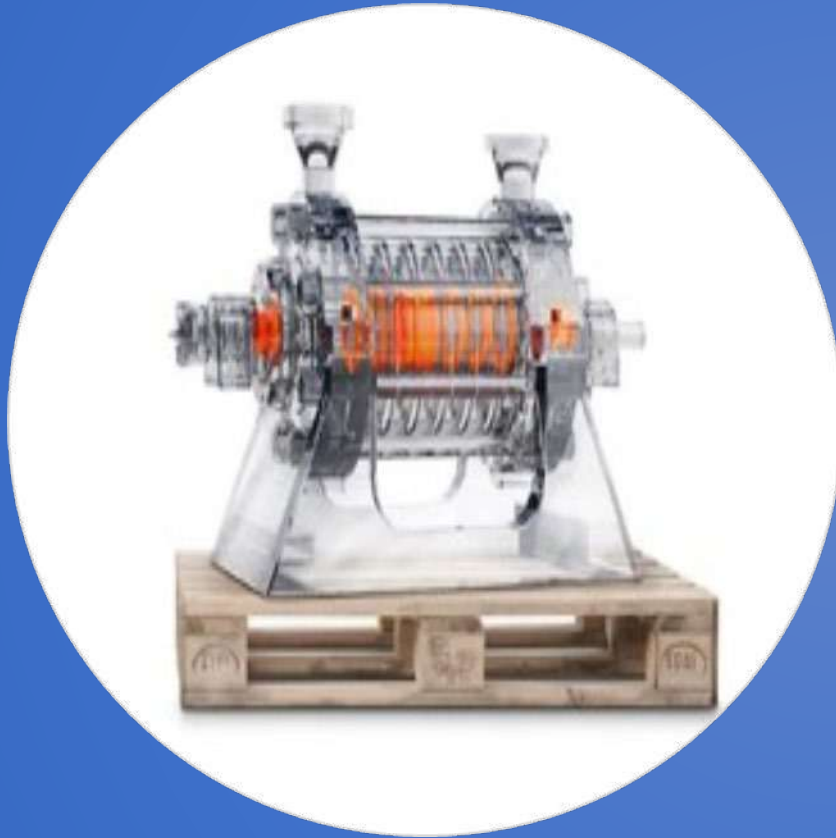

Retrofit and Modification

Capability to modify pumps as per the actual operating conditions for saving energy and extending operating life. Also renders an engineered solution for retro fitment service of competitor pump sets.



Replacement pump

Aftermarket support for one-to-one pump replacement and competitor pump replacement.



Field Service Support

Highly trained engineers reserved by KSB for rendering on field services to customer like commissioning, troubleshooting and consulting.

SPOG Kakinada - Flowline displacement Pump

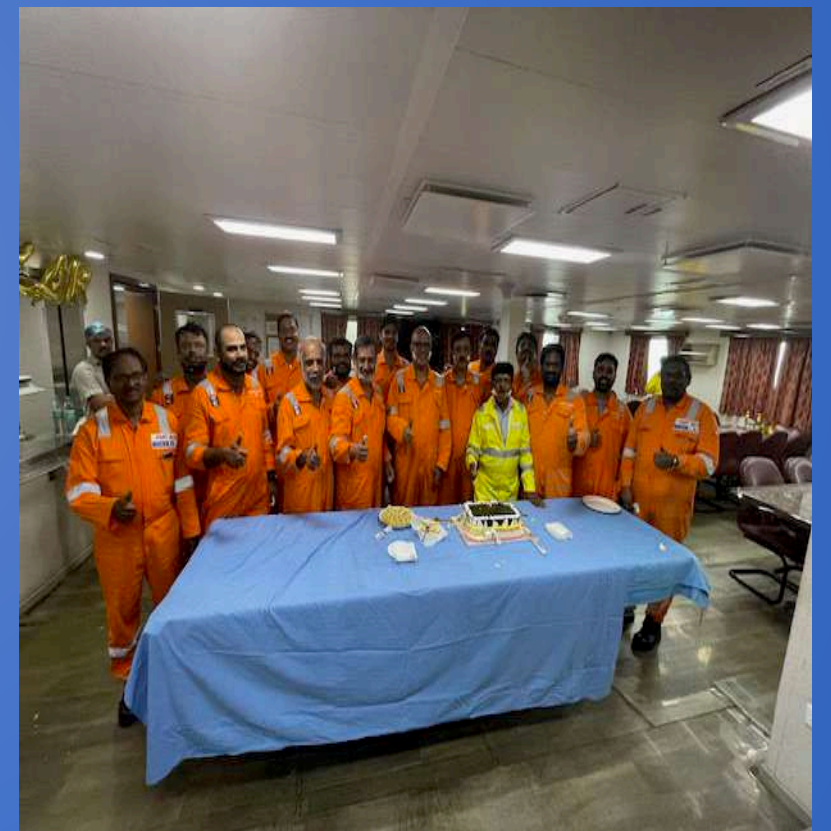



Reverse Engineering

- *A state of the art laboratory equipped with 3D scanning cameras and PMI testers.*
- *Supporting customers with :*
 - Replacements of original parts that are no longer available.*
 - Other make pump spare parts in stringent lead times specially for imported pumps.*
 - Longer service life with upgraded design, higher-quality or special material.*



Boiler Circulation Pump

One of the most critical application where KSB has attended expertise in. KSB offers a engineered solution in the form of overhauling or repair of BCPs at refurbishments facility in Pune.



Optimisation services

These services help customers to use pump systems more efficiently and durably. Recording of process variables and vibration levels through on-site measurements.



Automatic Recirculation Valve

A multifunctional valve whose primary function is to ensure a pre-determined minimum flow through the centrifugal pump at all times.

BP & CL Business

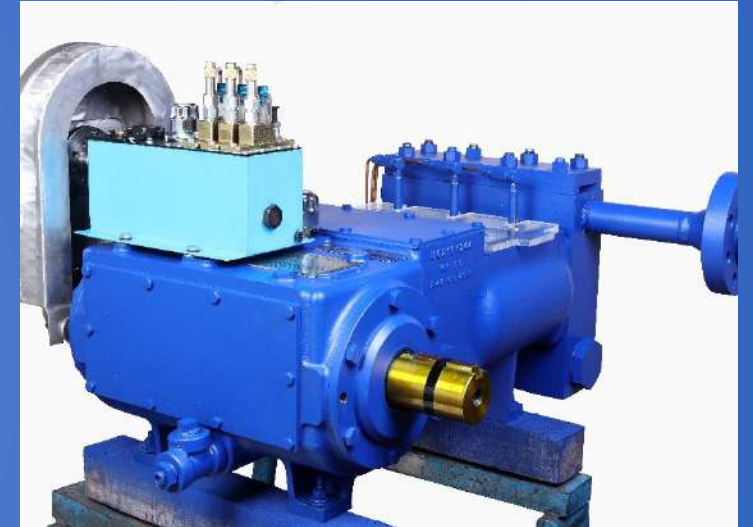

Bharat Pumps and Compressors Limited (BP&CL) is acquired by KSB Ltd. in early 2023. Allowing us to render services for BP&CL's make pumps.



Digitisation Services



KSB Guard

Pump Online Monitoring (IoT)

- *Increase system's efficiency*
- *Comprehensive & Real Time Monitoring*
- *Early detection of damage*
- *Optimize maintenance & Reduce downtimes*



KSB Sonolyzer® App

KSB Sonolyzer is a free App by KSB, with which you can estimate energy saving potentials by recording noises from rotating machines.



Scan the QR
code to
Download the
Mobile app



Being self-sufficient

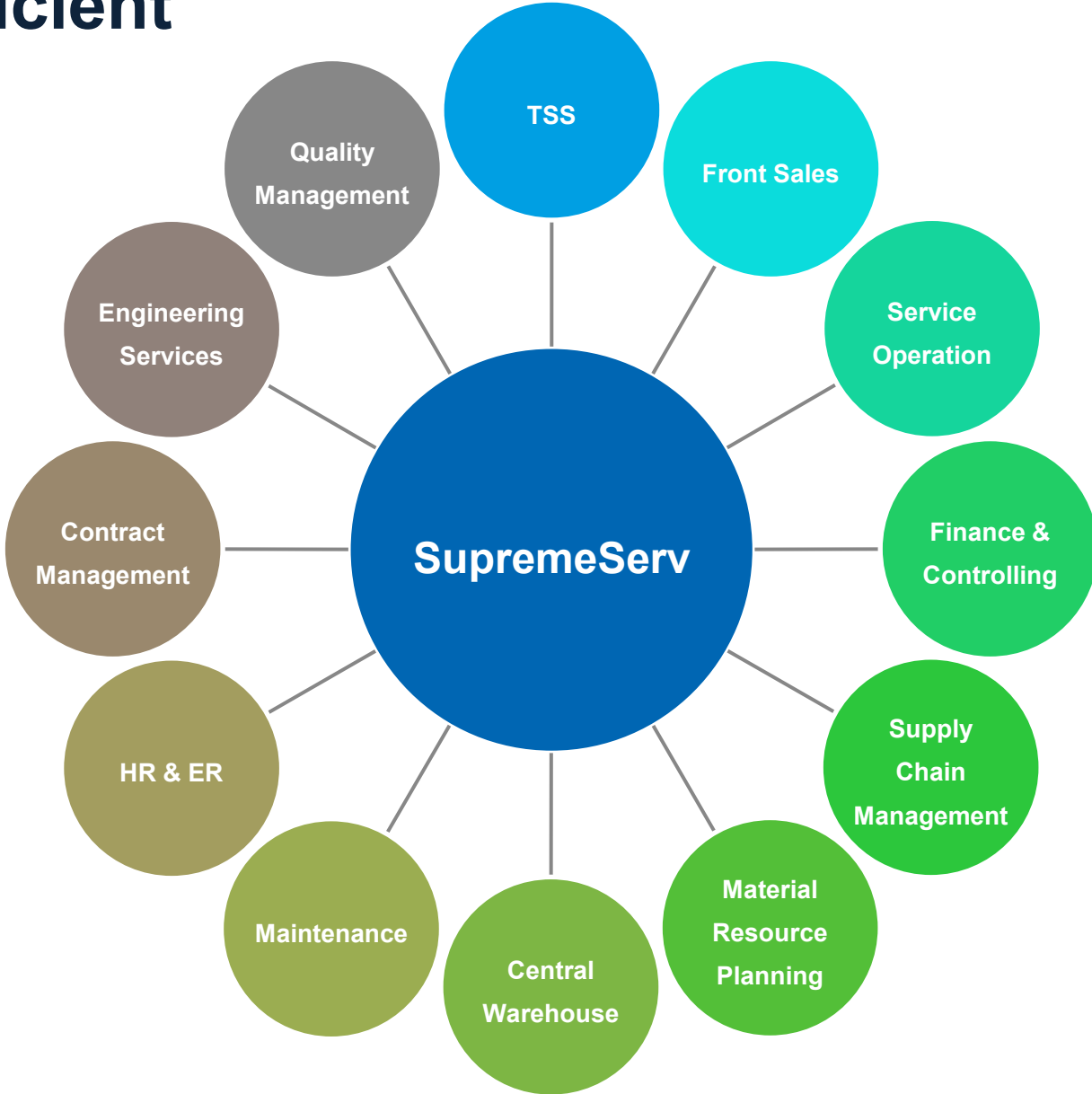

Energy, Health & Safety

Roof Top Solar

408.8

kWp
Power Generated

2.9 Mio

Estimated Savings
Per Year

10.7

Millions KGs CO₂
Lifetime Offset

13.05

Lacs Trees
Planting Equivalent

SupremeServ growth over years – Order Intake

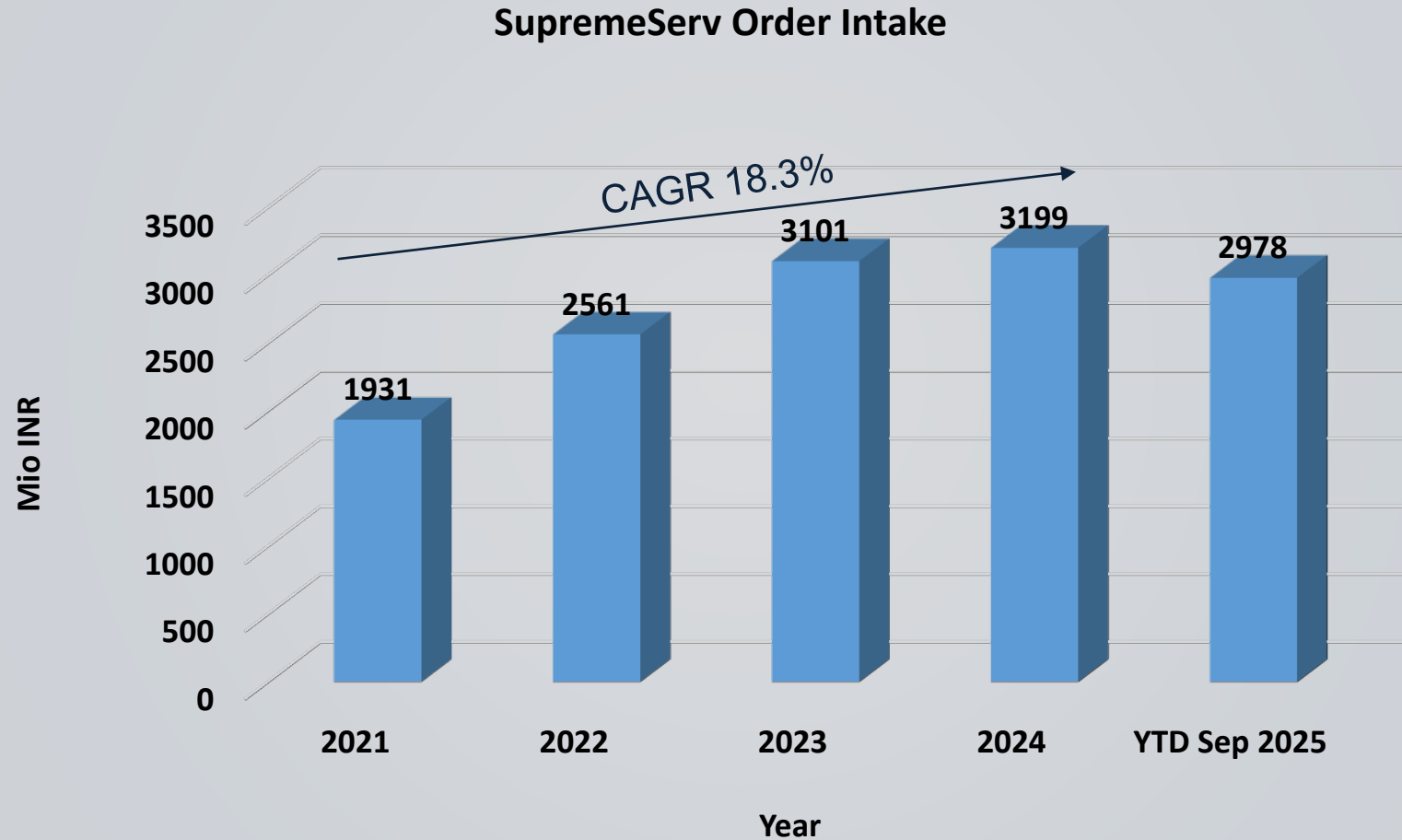

SupremeServ growth – Sales

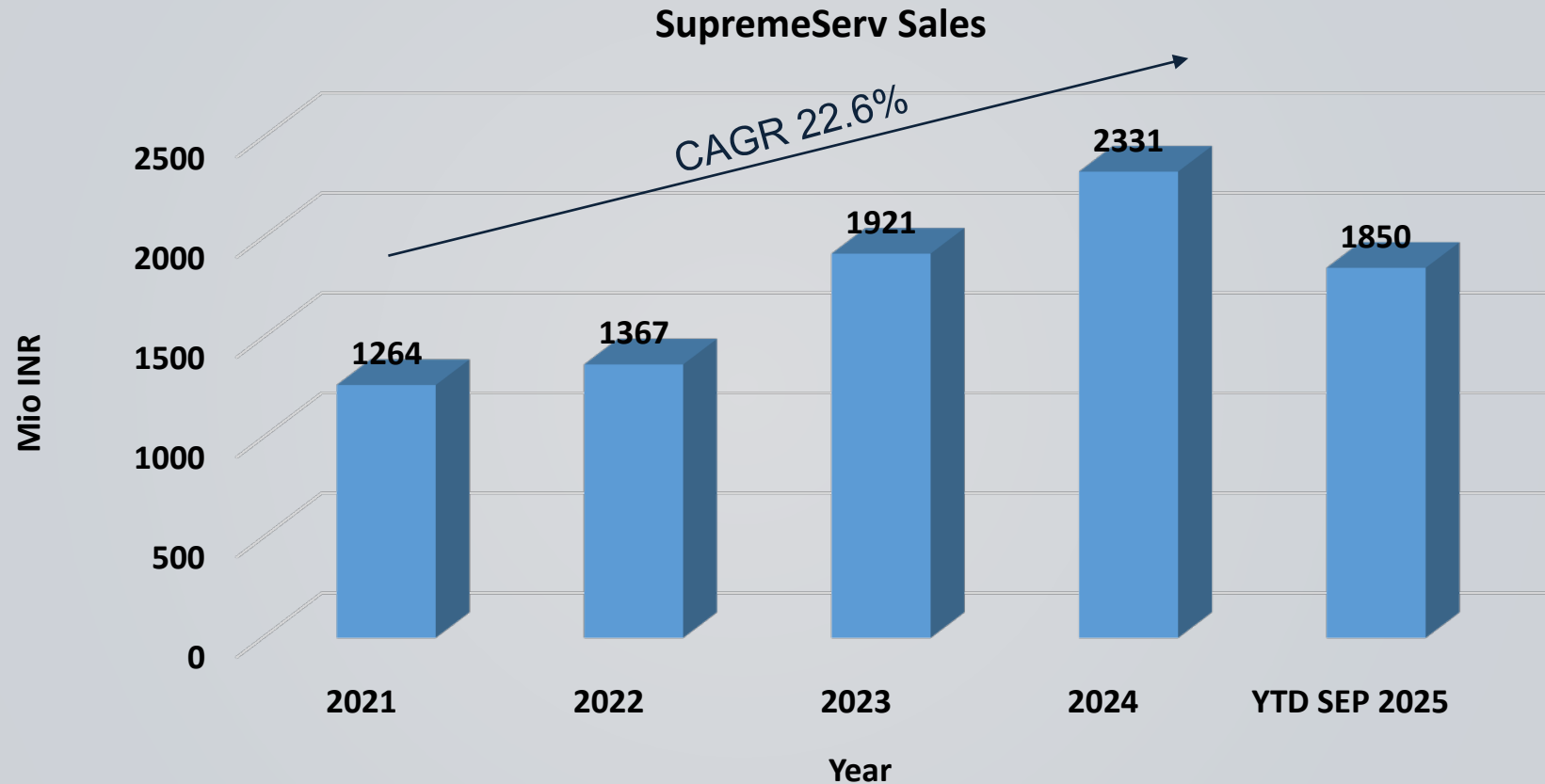

Way forward

Service partner network expansion

SupremeServ Academy

Infrastructure development

Business development via digital services



MISSION SUPREME



HIGHER... FASTER... STRONGER...

TOGETHER

KSB SupremeServ

Investors' Meet 17th Nov'2025 : Answering Your Questions!

Following the targets, not the headlines

KSB has a vision

KSB is executing the plan

We are convinced that success will continue

KSB Ltd. – Investor Meet Feedback



Thank you for joining!
We'd appreciate your feedback on the Investor Meet
It's optional – scan the QR code to share.