



Jamna Auto Industries Ltd.

May 29, 2026

To,
BSE Limited
Exchange Plaza, Plot No. C/1, G- Block,
Phiroze Jeejeebhoy Towers, Dalal Street,
Mumbai- 400001 Maharashtra
BSE Code: 520051

To,
National Stock Exchange of India Limited
Exchange Plaza, Plot no. C/1, G Block,
Bandra-Kurla Complex, Bandra (E)
Mumbai - 400 051, Maharashtra
NSE Code: JAMNAAUTO

Subject– Investors Presentation on the audited financial results for the quarter and year ended March 31, 2026.

Dear Sir/Madam,

Pursuant to the requirements of Regulation 30 and Regulation 46 of SEBI (Listing Obligations & Disclosure Requirements) Regulations, 2015, we are enclosing herewith the presentation by the Company pertaining to the audited financial results for the quarter and year ended March 31, 2026.

Kindly take the above information on records.

Thanking you,

Yours faithfully,
For Jamna Auto Industries Limited

Praveen Lakhera
Company Secretary & Head-Legal



Jamna Auto Industries Ltd.

Q4 FY25-26

INVESTOR PRESENTATION

India's Pioneer & Market Leader
in Automotive Suspension Solutions

BSE CODE
520051

NSE SYMBOL
JAMNAAUTO

DATE
29 May 2026

www.jaispring.com



SAFE HARBOR STATEMENT

This presentation and the accompanying slides (the "Presentation"), which have been prepared by Jamna Auto Industries Limited (the "Company"), have been prepared solely for information purposes and do not constitute any offer, recommendation or invitation to purchase or subscribe for any securities, and shall not form the basis or be relied on in connection with any contract or binding commitment whatsoever. No offering of securities of the Company will be made except by means of a statutory offering document containing detailed information about the Company.

This Presentation has been prepared by the Company based on information and data which the Company considers reliable, but the Company makes no representation or warranty, express or implied, whatsoever, and no reliance shall be placed on, the truth, accuracy, completeness, fairness and reasonableness of the contents of this Presentation. This Presentation may not be all inclusive and may not contain all of the information that you may consider material. Any liability in respect of the contents of, or any omission from, this Presentation is expressly excluded.

Certain matters discussed in this Presentation may contain statements regarding the Company's market opportunity and business prospects that are individually and collectively forward- looking statements. Such forward-looking statements are not guarantees of future performance and are subject to known and unknown risks, uncertainties and assumptions that are difficult to predict. These risks and uncertainties include, but are not limited to, the performance of the Indian economy and of the economies of various international markets, the performance of the industry in India and world-wide, competition, the company's ability to successfully implement its strategy, the Company's future levels of growth and expansion, technological implementation, changes and advancements, changes in revenue, income or cash flows, the Company's market preferences and its exposure to market risks, as well as other risks. The Company's actual results, levels of activity, performance or achievements could differ materially and adversely from results expressed in or implied by this Presentation. The Company assumes no obligation to update any forward-looking information contained in this Presentation. Any forward-looking statements and projections made by third parties included in this Presentation are not adopted by the Company and the Company is not responsible for such third party statements and projections.

MANAGEMENT COMMENTARY

A Defining year –

FY26 was a **defining year** for JAI, delivering its strongest-ever quarterly and full-year performance with record revenue and PBT. This performance was driven by a broad-based recovery across the M&HCV and LCV segments, supported by disciplined cost execution and strong aftermarket momentum.

During the year, JAI further strengthened its operational and strategic foundation

- **Commissioned New Capacities :-**
Adityapur (Parabolic Spring) and Indore (Leaf Spring and U Bolt)
- **Export New Customers**
Commenced Exports to Global Players Like Stellantis, expanding global footprint
- **After Market India**
Share of Allied Products in Aftermarket India Portfolio expanded to 8% up from 6% in FY 24-25
- **Manufacturing to Service:**
Established Pan-India trailer suspension service network with 29 Authorised Service Centre's, dedicated Training Centre at Pillaipakkam and digital Customer Care system
- **Launch of New Product**
Product Slipper Suspension :- Launch Slipper Suspension & Started Supply to Ashok Leyland
Drop Axle :- Launch Drop Axle & Started Supply to Ashok Leyland
- **Expansion of Customer Base for Existing Product**
Stabilizer Bar, Earlier Supplied to Tata Motors Ltd, now Commenced Supply to Mahindra & Mahindra Ltd

These milestones firmly establish the foundation for **Lakshya RISE 5000**, reinforcing JAI's long-term growth trajectory, scalability, and commitment to value creation



Mr. Randeep Singh Jauhar
Chairman & Executive Director

Q4 Results

Revenue	840
EBITDA	138/16.5%
PBT	116/13.8%
Cash Accruals (PAT + Depreciation).	104

JAI AT A GLANCE

From our beginnings in 1954 to market leadership today, JAI is India's largest and a global leader in tapered and parabolic leaf springs — with a growing portfolio that now includes lift axles and suspension systems, trusted by major OEMs.



10

MANUFACTURING
LOCATIONS



5,000+

PART NUMBERS



CARE A1+/AA
ICRA A1+/AA

SOUND CREDIT
PROFILE



20,000+ Touch Point

AMI NETWORK



17

EXPORT COUNTRIES

Product Portfolio

- Leaf Springs
- Parabolic Springs
- Stabilizer Bar
- Lift Axle
- Drop Axle
- Slipper Suspension
- Trailer Suspension
- Allied Products

Revenue Mix

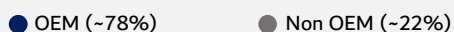

Marquee Customers

- Tata Motors
- Ashok Leyland
- Bharat Benz
- VE Commercial Vehicles
- Mahindra
- Fuso
- Vovlo
- Force Motors
- ISUZU
- SCANIA
- SML Isuzu
- TADANO Escort
- UD Trucks

Robust Infrastructure

Proximity:

Plants located near key OEM hubs

Scale:

Low cost producer with economies of scale.

R&D:

In-house R&D center for product design & testing.

Distribution:

Pan-India aftermarket network with digital integration.

STRATEGIC ROADMAP

LAKSHYA RISE 5000

Our blueprint for the next phase of accelerated growth and value creation

- Target is to achieve Rs. 5,000 crores Revenue, New Markets (Indian After Market +Export) to be 40% of Revenue, deliver 40% ROCE and 50% Dividend payout.
- As we go further, to ensure lasting value, we are deepening our focus on New Markets
- This strategic shift empowers us to maintain steady performance not only in periods of economic expansion, but also remain stable and reliable, no matter the macro environment.
- As we embark on this journey, every action is aligned to propel us into the league of growth champions. Together, we RISE to new horizons.



	REVENUE TARGET	NEW MARKETS	ROCE	DIVIDEND PAYOUT
RISE 5000	₹ 5,000 Cr	<small>Indian After Market +Export</small> 40%	40%	50%

FINANCIAL TRENDS - QUARTELRY

Profit & Loss Statement

All Figure are in INR Crores

Consolidated QOQ

Particulars	Q4 FY 25-26	Q3 FY 25-26	QoQ	Q4 FY 24-25	YoY
Net Sales	840	668	26%	638	32%
EBITDA	138	105	31%	85	62%
PBT	116	83	40%	72	61%
PAT	87	58	50%	50	74%

FINANCIAL TRENDS - YEARLY

Profit & Loss Statement

All Figure are in INR Crores

Consolidated YOY

Particulars	12 Months FY 25-26	12 Months FY 24-25	YoY
Net Sales	2612	2270	15%
EBITDA	394	307	28%
PBT	320	256	25%
PAT	231	180	28%

GEOGRAPHIC EXPANSION STRATEGY- Total Plants 10

India Manufacturing Footprint Strategic proximity to key OEM hubs

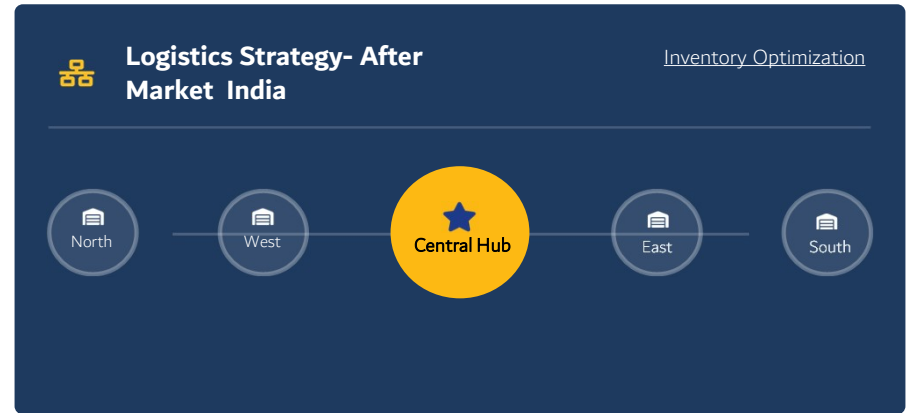
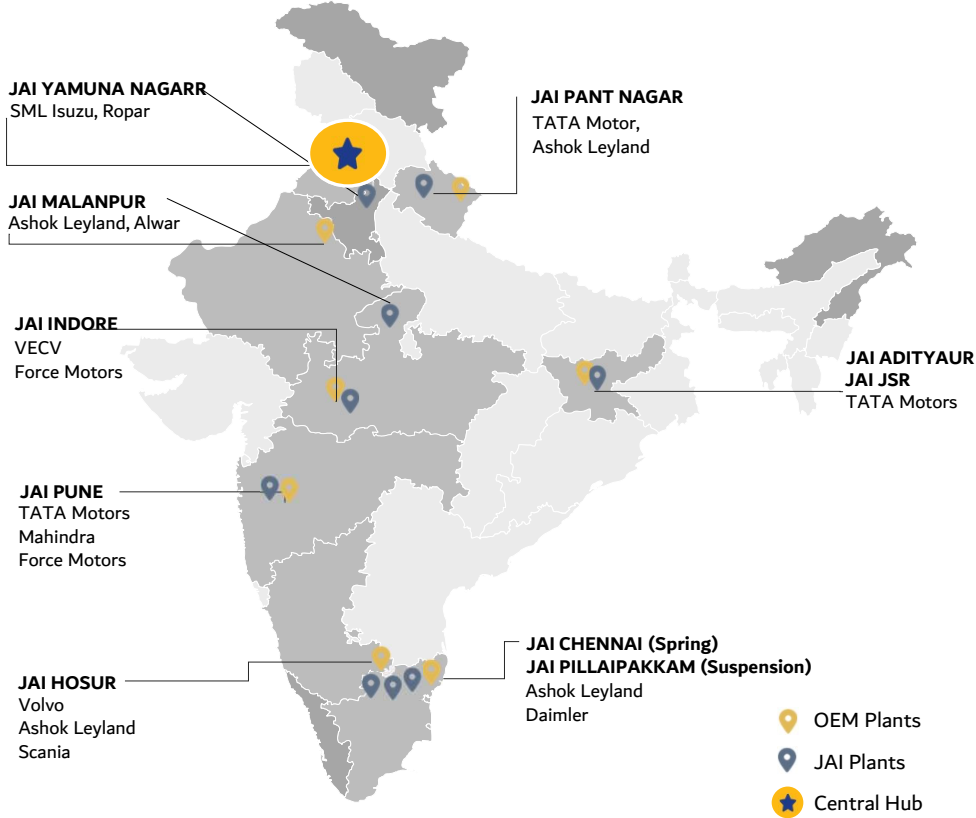

MILESTONES & EVOLUTION

1954

FOUNDING ERA

- ✓ Established as a spring manufacturing unit
- ✓ Early focus on spring assembly and repairs
- ✓ Laid foundation for engineering excellence

1990-2010

EXPANSION

- ✓ Established national manufacturing footprint
- ✓ Became key supplier to major OEMs
- ✓ Modernized plants with new technology.
- ✓ Merged 3 entities for Economies of Scale and Better Corporate governance
- ✓ Infused funding from Private Equity to replace high Cost Debt and Support expansion

2011-24

DIVERSIFICATION

- ✓ Scaled up aftermarket business significantly
- ✓ Launched new products
 - Heavy Parabolic Springs :
 - Spring Allied
 - Lift Axles
 - Trailer- Air Suspension & Mechanical Suspense
 - Allied Components

FY20-++
DIGITAL ERA

- ✓ JAI Connect
- ✓ Data Analytics
- ✓ DMS
- ✓ ERP Whatsapp Bot

FY26+

FUTURE READY

- ✓ Started Manufacturing U-Bolt
- ✓ Capacity expansion: Indore, Jharkhand
- ✓ Establishing New Facilities for integrated suspension system plant including in house manufacturing of Axle & Rubber

INDUSTRY HIGHLIGHTS

Highlights

For the Quarter

All Figure are in INR Crores

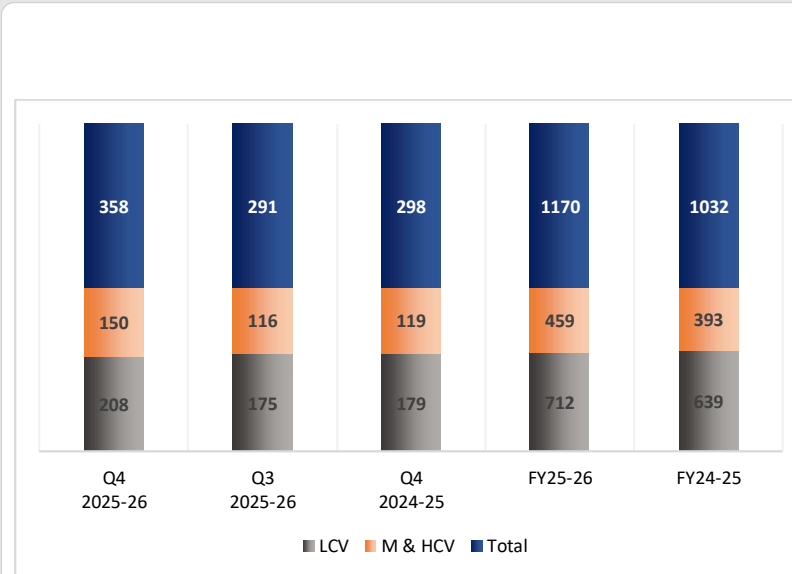

QoQ
Change %

YoY
Change %

23%

20%

29%

26%

19%

16%

Data Source-SIAM

LCV Production Changes

- ↑ - Q4 FY26 vs Q3 FY26 - 19% Increase
- ↑ - Q4 FY26 vs Q4 FY25 - 16% Increase

M&HCV Production Changes

- ↑ - Q4 FY26 vs Q3 FY26 - 29% Increase
- ↑ - Q4 FY26 vs Q4 FY25 - 26% Increase

REVENUE MIX & PRODUCT MIX

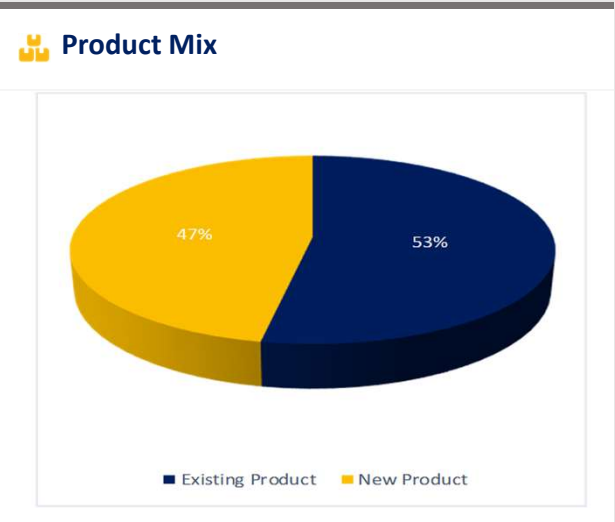
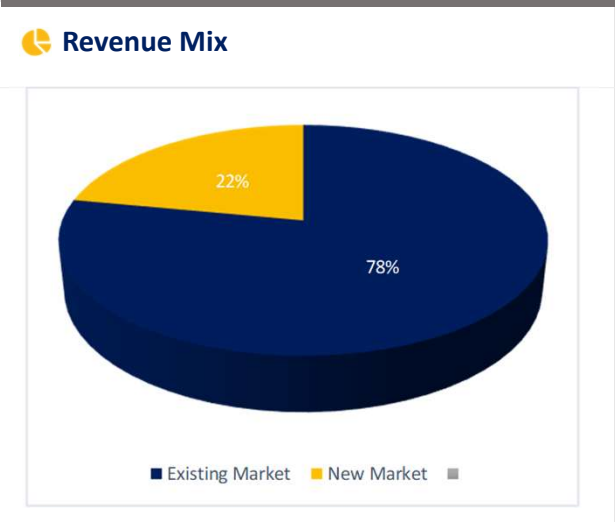

DIGITAL TRANSFORMATION JOURNEY

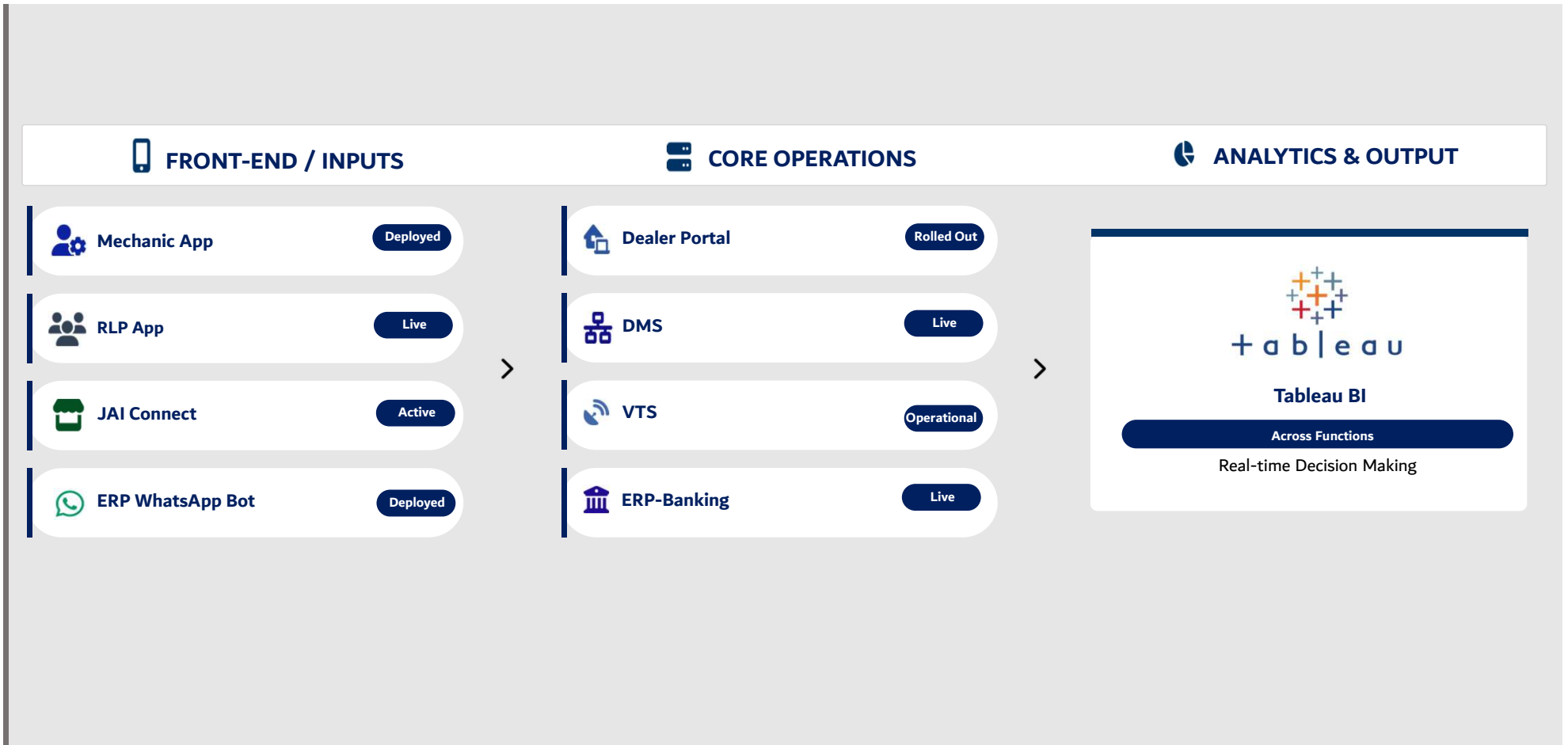

INNOVATION & R&D SHOWCASE

World-Class R&D Infrastructure

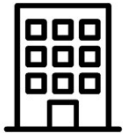

In-House R&D Centre



Fatigue Test Rigs



FEA & Simulation



Prototyping Lab

JAI is constantly adapting to evolving technology in order to keep up with the times and offer its clients cutting-edge products. The company uses the best equipment that complies with international standards. The development of in-house technological capabilities for the design and production of innovative suspension products is given significant consideration by JAI.

Our Achievements

- First to Introduce Parabolic Spring for Indian Roads
- First to start Leaf Spring Design Centre in India
- In House R&D Centre with full Design, Simulation, and Validation Capabilities ,capable to design Multi, Parabolic Leaf Spring, Lift Axle and Air Suspension for all automobile applications

IP Portfolio

- 140+ copyrighted designs across springs and suspension products.
- Patents for air suspension systems (including trailer applications)
- “JAI” trademark registered in 16 countries

CORPORATE GOVERNANCE FRAMEWORK

Governance Structure



Risk Monitoring & Controls

Centralized Decisions

Unified framework for strategic alignment

Cross-Functional Teams

CFTs for strategic initiative execution

Periodic Reviews

Monthly/Quarterly management cadence

Internal Audit

Continuous monitoring program

Risk Dashboards

Real-time escalation protocols

Compliance & Policy Framework

✓ SEBI LODR Regulations

✓ Related Party Transactions

✓ Code of Conduct & Ethics

✓ ESG Oversight Framework

✓ Whistleblower Policy

✓ Cyber Security Policy

SHAREHOLDING PATTERN

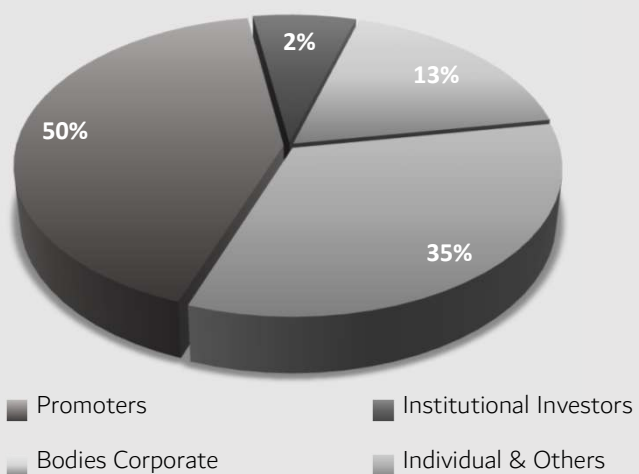

Categories	% Holding as on 31.03.2026	% Holding as on 31.03.2025
Promoters	50%	50%
Institutional Investors	13%	8%
Bodies Corporate	2%	2%
Individual & Others	35%	40%
Total	100%	100%



ESG & CSR

ESG ROADMAP & TARGETS

FY 2030

Sustainability Vision

Sustainability Roadmap towards ESG KPIs

- I. Accelerating Decarbonization: Reduction of 18% (Baseline H2FY2025)
- II. Renewable Energy transition: RE usage upto 80% (Baseline FY2025)
- III. Water Stewardship & Neutrality: Reduction of 75% (Baseline FY2025)
- IV. Promoting Circular Economy: 100% Waste Recycled (Baseline FY2025)
- V. Towards Zero Plastic: Reduction of 100%. (Baseline FY2025)
- VI. Diversity & Inclusion: 10% Gender diversity ratio
- VII. Employee safety & well being

- I. Focused transition to green fuels and renewable energy, infrastructure upgrades, and strategic initiatives.
- II. Expanding the renewable energy footprint across all manufacturing plants.
- III. Adherence to the Reduce–Reuse–Recharge principle for water stewardship.
- IV. Reducing waste through process innovation, reuse, and sustainable disposal.
- V. Adopting sustainable alternatives and eliminating single-use plastics across the value chain.
- VI. Increasing female workforce participation to foster gender diversity and inclusive growth.
- VII. Driving employee well-being with a zero-accident culture, ISO 45001 standards, and focus on work ergonomics and training.

CONTRIBUTING TO THE SOCIETY

We are committed to contribute to the social and economic welfare of communities in which we operate. Playing an active role in sustaining positive change within society. We aim to create opportunities for the holistic development of people from all sections of society.

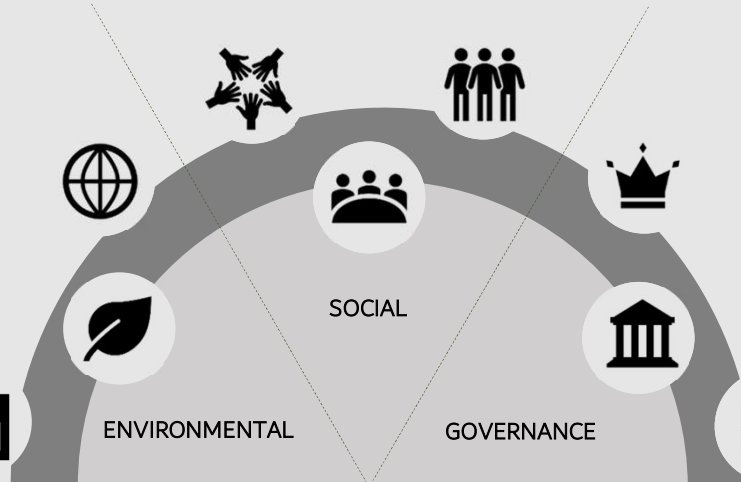

CONTRIBUTING TO THE SOCIETY



Environment

- 700 saplings planted in Yamuna Nagar, Chennai, Malanpur, Housr, Jamshedpur & Pune.
- Installed 500 bird stations in parks, schools and colleges, forest areas in Delhi, NCR & Yamuna Nagar.
- Installed 25 dustbins in Govt. offices and community health centers in Jamshedpur.
- Distributed 650 jute/cloth bags to employees, students and community people to discourage use of plastic bags in Delhi & Pune
- Celebrated World Forest Day & World Water Day by sensitizing more than 1500 beneficiaries in Malanpur, Chennai & Gurgaon.



Education

- Awarded annual scholarship to 503 meritorious students in GNK college, institute & Akaal University, Bhatinda
- Improved basic facilities and infrastructure in 16 Government schools and 8 Anganwadi centers in Yamuna Nagar, Jamshedpur, Chennai, Pune & Bhatinda.
- Established 02 public library in District Jind, Haryana.
- Installed 04 sanitary pad vending machines with incinerator and provided 2500 sanitary pads for girl students in 03 Govt. Sr. Sec. schools in Yamuna Nagar & a private school run by NSG wing in Gurgaon.
- 2090 rural students sensitized on oral hygiene by distributing free dental kits distributed in primary schools in Yamuna Nagar, Pillaipakkam, Pant Nagar & Jamshedpur.

Skill:

- 175 youths and women were awarded certificates in computer and sewing course in Delhi & Yamuna Nagar

CONTRIBUTING TO THE SOCIETY



Sports

- Sponsored monthly diet money to 18 sportspersons in GNK College, YNR.
- Awarded annual sponsorship to 30 sportspersons in GNK College YNR.
- Installed 02 open gym & swings for prison staff and their families in District Prison, Gurgaon & Yamuna Nagar
- Provided high jump pit and equipment for training of young athletes in Tau Devi Lal Sports Complex, Gurgaon
- Provided squash kits to 03 young needy sportsperson getting trained in Siri Fort Sports Complex, Delhi
- Distributed sports equipment and uniform to needy students in Govt. schools, Pillaipakkam and Jamshedpur.
- **Key Achievement:** Our sponsored athlete Nuzrat Ali ranked 3rd position in 60 meter run in 1st National Indoor Athletics Championship held in Bhubaneswar, Odisha



Community Reach

- Distributed nutrition kits to 400 needy TB patients in Pant Nagar & Gurgaon on monthly basis.
- Financial supported 43 cataract surgeries in Yamuna Nagar & Malanpur
- 270 patients were screened in 02 multispecialty health camps in YNR & MLP.
- Celebrated International Women's Day to honor women's contributions in society and created awareness on gender issues in Chennai, Hosur, MLP, YNR & JSR
- Sponsored "Digital Saheli app" an initiative of Gurgaon Police for empowering women digitally.
- Constructed 40 individual toilets in BPL families in Yamuna Nagar
- Improved basic facilities in cremation grounds by making shed, water tank, installed benches in Yamuna Nagar
- Installed 46 street light in YNR & Gurgaon
- Installed RO system (1000 litter capacity) to ensure filter water for villagers in Kharadwal village, Jind
- 65 wheelchairs gifted to PWD's in Jaipur & Chennai
- 650 blankets distributed to tribal families in Jamshedpur & labours in Yamuna Nagar.

CUSTOMER CONCENTRATION & DIVERSIFICATION

OEM Customers



CUSTOMER CONCENTRATION & DIVERSIFICATION



Aftermarket Network

350+
Distributors

20K+
Retailers

25K+
Mechanics



PRODUCT PORTFOLIO & APPLICATIONS

Comprehensive Suspension Solutions



Conventional Leaf Spring



Hybrid Leaf spring Assembly



Z-Spring



Parabolic Leaf Spring



Stabilizer Bar

PRODUCT PORTFOLIO & APPLICATIONS

Comprehensive Suspension Solutions



Bus Air Suspension



Lift Axle

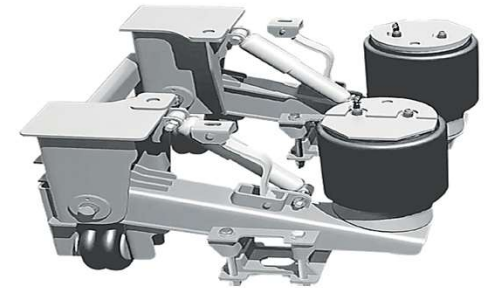

Trailer Air Suspension

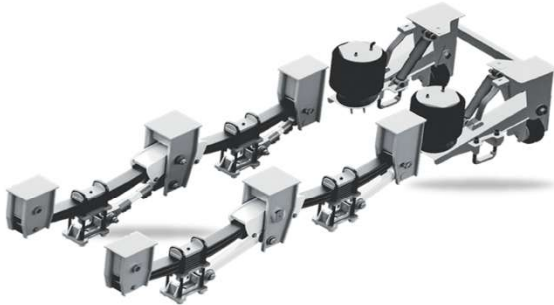

Trailer Mechanical and Air Suspension with Lift Axle



Trailer Mechanical Suspension

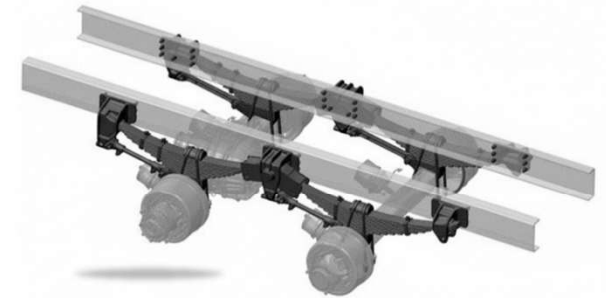

Slipper Suspension

PRODUCT PORTFOLIO & APPLICATIONS

After Market India JAI's Product Portfolio

